



ABN 44 071 568 771

"A-Z Product Solutions for Trade and Industry"

sales@all-trades.com.au

www.all-trades.com.au

RIP-A-LABELS

DESCRIPTION

- Each colour suits a different application
- Telstra Approved design
 - CAT V Earth Bond
 - CAT V Feeder Cable
 - CAT V Drop Cable
 - CAT V Power Blocking Device
 - Power Block



TERMINATION JIG

DESCRIPTION

- Designed for Quante Modules



RAYCHEM TELSTRA CABLE END

DESCRIPTION

- Allows for heat shrinking of cut cable ends
- Prevents weather ingress and corrosion of cable internals
- Come in sizes to suit any cable application



75 OHM TERMINATOR/RESISTOR

DESCRIPTION

- Covering unused ports in service taps
- Prevents weather ingress of unused service ports



Sydney Office
11/5 Hudson Ave
Castle Hill NSW 2154
Ph: 02 8850 2700



Melbourne Office
4/5 Kelletts Rd
Rowville VIC 3178
Ph: 03 9780 4850



ABN 44 071 568 771

"A-Z Product Solutions for Trade and Industry"

sales@all-trades.com.au

www.all-trades.com.au



SIEMENS 2000 TEST LEAD ADAPTOR

ATM-CZ23003

- Suits Quickswitch Handle

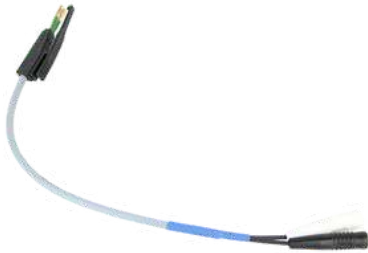

R&M MADISON TEST LEADS FOR CMUX 2 POLE

MADMTVS10/201

- Suits CMUX 2 Pole



LEAD SET W/CROC CLIPS

ATM-SEW-AL-36RYG



Sydney Office
11/5 Hudson Ave
Castle Hill NSW 2154
Ph: 02 8850 2700



Melbourne Office
4/5 Kelleys Rd
Rowville VIC 3178
Ph: 03 9780 4850

TUCSON TC-28

DESCRIPTION

TC-28 Handheld Fibre Optic Inspection Probe is a portable video microscope used to examine installed fibre terminations or ensure terminations are smooth and clean.

CONTENTS

- Inspection Probe Microscope
- Universal Adaptors for Inspection
- High Precision 3.5" TFT Display Screen
- Elastometric Boot & Brightness Adjustment to get a clear view of fibre strands



TUCSON TC-40

DESCRIPTION

TC-40 is designed to aid in the testing of fibre optic cable when using an OTDR. The OTDR Launch Fibre box is used with Optical Time Domain Reflectometers (OTDR's) to help minimize the effects of the OTDR's launch pulse on measurement uncertainty.

CONTENTS

- Pulse Suppressor, Launch Box, Delay Line, Installation/Testing, Training, Calibration
- Compound Latch for positive seal and easy opening with locking feature
- Non-metal construction will not dent, corrode, or conduce electricity
- Water and dust proof allowing the unit to be taken into almost any environment
- Case can house up to 2,000 meters of fibre
- Auto Purge Valve for changes in altitude and temperature

Length x Width x Height	9.37" x 5.56" x 2.62"
Material	SR Polypropylene
Color	Black/Yellow
Weight	0.75 kg (without fiber)
Operating temperature	-40°C ~ +55°C
Typical Loss	< 0.5dB @ 1310nm for 1000 meters



TUCSON TC-55

DESCRIPTION

TC-55 is a full-function optical power meter. It aims at fibre network installation, fibre network engineering acceptance and fibre network maintenance.

Sub Model	TC-55A	TC-55B
Measurement Range(dBm)	-70 ~ +3	-50 ~ +26
Detector Type	InGaAs	
Detector Area	Ø 0.3mm	
Uncertainty(dB)	±0.15 (3.5%)	
linearity (dB)	±0.02	
Calibrated Wavelength(nm)	850, 1300, 1310, 1490, 1550, 1625	
Display Resolution(dB)	0.01	
Frequency ID(Hz)	270, 1K, 2K	
Wave ID(nm)	850, 1300, 1310, 1490, 1550, 1625	
Date storage capacity	1000	
Communication Port	USB	
Optical Connector	FC/SC/ST(FC-LC converter is optional)	
Power Supply	Alkaline Battery (3 AA 1.5V batteries)	
Battery Operating Time	200h	
Operating Temperature(°C)	-10 ~ +60	
Storage Temperature(°C)	-25 ~ +70	
Relative Humidity	0 to 95% (non-condensing)	
Dimension(mm)	200 X90 X50	
Weight(g)	285	

FEATURES

- Wave ID Automatic wavelength identification and switching (combined with handheld light source)
- Frequency ID/Tone detection Automatic frequency identification
- Data storage function: Up to 1000 test records
- USB communication port to download the saved testing records
- Reference power level can be set up and stored
- Auto-off function can be activated or deactivated



TUCSON

TUCSON TC-65

DESCRIPTION

TC-65 Optical Light Source is one of Tucson's latest self developed test instruments. Together with Optical Power Meter, it acts as a perfect solution for working on the fibre optic network.

FEATURES

- Tone generation: 270HZ, 1KHZ, 2KHZ
- Output power value is shown on LCD display
- Intelligent backlight control (light intensity can be adjusted properly according to ambient light, which greatly reduced power consumption)
- AA alkaline for power supply

Sub Model	TC-65A	TC-65B	TC-65C	TC-65D	TC-65E	TC-65F	TC-65G
Wavelength (nm)	1310/1550	850/1300	1310/1490/1550	850/1300/1310/1550	850/1300 1310/1490/1550	1310/1550/1625	850/1300 1310/1550/1625
Applicable fiber	SM, MM						
Laser type	FP-LD (others specify on requests)						
Maximum Output Power	-7 dBm (can be adjustable and others specify on requests)						
Stability (dB, 15min, 20°C)	±0.1						
Stability (dB, 30min, 20°C)	±0.05						
Modulation (Hz)	CW, 270, 1K, 2K						
Optical Connector	FC/SC/ST (FC-LC converter is optional)						
Power Supply	Alkaline Battery (3 AA 1.5V batteries)						
Battery Operating Time	45h with 1.5V Battery (3)						
Operating Temperature (°C)	-10 ~ +60						
Storage Temperature (°C)	-25 ~ +70						
Relative Humidity	0 to 95% (non-condensing)						
Dimension (mm)	200 X 90 X 50						
Weight (g)	285						



TUCSON

3M HAND CRIMPING TOOL

DESCRIPTION

This hand crimping tool is designed to work with UR2-D, 211, UR, UR2, UG, UY2, UAL, UPB, UP3, UCC, UB2A-D, UY, UP2, UY2-D, UB2A, UPC. The maximum supported wire size is 20 awg.



KLEIN COAX CABLE CONTINUITY TESTER

DESCRIPTION

Identifies and tests for continuity, shorts and location via loud audible beep and LED indicators

FEATURES

- Docked remote switches tester off to conserve battery life
- Audible Remote contains loud beep for easy location identification
- Non-Slip Cushion-Grip Handle for comfort and secure grip of tool
- F-Adapter (included) enables testing of loose cable and installed cable runs
- Pocket Clip secures tester to shirt pocket



AMP TRIMMING TOOL (HFC) POTENTIOMETER

DESCRIPTION

- Double-ended moulded plastic trimming tool for single and multi-turn presets, with a protruding blade at one end and a shrouded blade at the other.



RIGHT ANGLE KS → KS ADAPTOR

DESCRIPTION

- Designed for installations where space restrictions require right angle connections between coaxial cables.



KS PORT HOUSING TERMINATOR (HFC)

DESCRIPTION

- Telstra Approved



CABLE FORMING TOOL (SUITS .750 COAX HFC CABLE)

DESCRIPTION

- Suits .75 COAX HFC Cable



GREENLEE A340 PHONE TEST SET "BUTTINSKI"

DESCRIPTION

The Alert 340 test telephone is a robust device for use in applications where DigAlert™ circuit technology is not necessary. DSP (Digital Services Patronage) devices have been developed for the safe application with cables that are active digital traffic, the voltage supply for remote devices or dangerous voltage on the basis of errors or incorrect use of the lines.

FEATURES

- Display-backlit LCD and glow-in-the-dark keypad
- DataSafe Pro-superior high-impedance monitoring, lockout and override, making you completely safe in any mode
- DropSafe-passes 20-foot drop test
- DSL/POTS Filtering Technology-allows technicians to clip on a live DSL line
- to test POTS service without downing or disrupting data service
- RainSafe—designed for use in rain conditions.
- 2-way hands-free speakerphone-for true hands-free conversation



AMP TRIMMING TOOL (HFC) POTENTIOMETER

DESCRIPTION

- Double-ended moulded plastic trimming tool for single and multi-turn presets, with a protruding blade at one end and a shrouded blade at the other.



RIGHT ANGLE KS → KS ADAPTOR

DESCRIPTION

- Designed for installations where space restrictions require right angle connections between coaxial cables.



KS PORT HOUSING TERMINATOR (HFC)

DESCRIPTION

- Telstra Approved



CABLE FORMING TOOL (SUITS .750 COAX HFC CABLE)

DESCRIPTION

- Suits .75 COAX HFC Cable





ABN 44 071 568 771

"A-Z Product Solutions for Trade and Industry"

sales@all-trades.com.au

www.all-trades.com.au



EQUIBOND

EQUIBOND

- EQUIPOTENTIAL Bond
- Bonds equivalent potential differences
- Gator Clips
- Sleeves



TELSTRA LEAD IN CABLE ID LABEL

ATM141/389



TX916 LEAD SET

TEL-12910



Sydney Office
11/5 Hudson Ave
Castle Hill NSW 2154
Ph: 02 8850 2700



Melbourne Office
4/5 Kelleys Rd
Rowville VIC 3178
Ph: 03 9780 4850



CST750 INSERT REPLACEMENT

PHIC163.6



PHASE SEQUENCE TESTER EXTENSION LEADS (1.2M)

ATM-HMM-HFPM-12



KS PORT TEST PROBE

PHIC.SV05

- Power Blocked
- 20dB
- 1GHz

DEXGREEN CLOSURE SEALANT KIT DEXBOND 10B

DESCRIPTION

Dexbond 10B sealant is a unique polyurethane sealant that ensures telecommunications joints and cables are effectively sealed against the ingress of water and water vapour.

FEATURES

- Easy to use
- Quick curing @ Ambient Temperatures
- Dispensed from a hermetically sealed coaxial cartridge system, the Dexbond sealant becomes an inert and safe material once mixed through the mixing nozzle and applied.
- A specially developed re-sealable coaxial cartridge enables greater control over application and reduces waste
- Closure types: The sealant can be used to seal optical fibre cables and heat shrinkable ported base closures and with resin-filled closures of all shapes and sizes
- Repair: Dexbond 10B is ideal sures of all shapes and sizes
- Dexbond 10B sealant is a unique polyurethane sealant that ensures telecommunications joints and cables are effectively sealed against the ingress of water and water vapour.



DEXGREEN

RG6 CABLE STRIPPER PREP TOOL

DESCRIPTION

- Designed for Industry standard RG6 cable stripping
- Enclosed blade design



FEMALE SPLICE ADAPTOR (3GHZ)

DESCRIPTION

PPC F Female Splice Adapter, 3GHz, Indoor Wall Plate Version, Telstra Approved
100 Included in pack



JONARD HIGHFIELD PEDESTAL KEY

DESCRIPTION

The barrel lock plunger key is compatible with several types of Highfield and Inertite barrel locks with inside diameters ranging from .176" to .196". These locks are used by utility companies including CATV, telecom, power, water, gas, plus others.

FEATURES

- Made of high carbon alloy steel for heavy-duty use and engineered for superior tamper resistance
- Smooth plunger and heavy-duty spring designed for high strength and durability plus the tool is serialized for extra protection
- Designed only for the CATV barrel locks mentioned above, does not work with other locks including those for electric and gas meters



HANLONG COAX CABLE STRIPPER

FEATURES

- Constructed of tough injection molded thermoplastic
- Built-in tension spring
- Centre conductor cutter
- Slide adjustment
- No replacement cassette is needed
- Fixed 3-Blade Construction
- Strips Cable-Jacket, Shield, Insulation.
- Stripping Length: This stripper can strip cable in twolengths 10 and 12 mm (Stripping length is preset to 12 mm)
- 3-blades model



JONARD HIGHFIELD PEDESTAL KEY

DESCRIPTION

The barrel lock plunger key is compatible with several types of Highfield and Inertite barrel locks with inside diameters ranging from .176" to .196". These locks are used by utility companies including CATV, telecom, power, water, gas, plus others.

FEATURES

- Made of high carbon alloy steel for heavy-duty use and engineered for superior tamper resistance
- Smooth plunger and heavy-duty spring designed for high strength and durability plus the tool is serialized for extra protection
- Designed only for the CATV barrel locks mentioned above, does not work with other locks including those for electric and gas meters



HANLONG COAX CABLE STRIPPER

FEATURES

- Constructed of tough injection molded thermoplastic
- Built-in tension spring
- Centre conductor cutter
- Slide adjustment
- No replacement cassette is needed
- Fixed 3-Blade Construction
- Strips Cable-Jacket, Shield, Insulation.
- Stripping Length: This stripper can strip cable in twolengths 10 and 12 mm (Stripping length is preset to 12 mm)
- 3-blades model



3M HAND CRIMPING TOOL

DESCRIPTION

This hand crimping tool is designed to work with UR2-D, 211, UR, UR2, UG, UY2, UAL, UPB, UP3, UCC, UB2A-D, UY, UP2, UY2-D, UB2A, UPC. The maximum supported wire size is 20 awg.



KLEIN COAX CABLE CONTINUITY TESTER

DESCRIPTION

Identifies and tests for continuity, shorts and location via loud audible beep and LED indicators

FEATURES

- Docked remote switches tester off to conserve battery life
- Audible Remote contains loud beep for easy location identification
- Non-Slip Cushion-Grip Handle for comfort and secure grip of tool
- F-Adapter (included) enables testing of loose cable and installed cable runs
- Pocket Clip secures tester to shirt pocket



AMP TRIMMING TOOL (HFC) POTENTIOMETER

DESCRIPTION

- Double-ended moulded plastic trimming tool for single and multi-turn presets, with a protruding blade at one end and a shrouded blade at the other.



RIGHT ANGLE KS → KS ADAPTOR

DESCRIPTION

- Designed for installations where space restrictions require right angle connections between coaxial cables.



KS PORT HOUSING TERMINATOR (HFC)

DESCRIPTION

- Telstra Approved



CABLE FORMING TOOL (SUITS .750 COAX HFC CABLE)

DESCRIPTION

- Suits .75 COAX HFC Cable





CST750 INSERT REPLACEMENT

PHIC163.6



PHASE SEQUENCE TESTER EXTENSION LEADS (1.2M)

ATM-HMM-HFPM-1.2



KS PORT TEST PROBE

PHIC.SV05

- Power Blocked
- 20dB
- 1GHz



MADISON TERMINATING TOOL FOR CMUX

MADR300069

- Genuine R&M tool for wiring all VS compact modules. The wires are contacted and cut to length in a single and efficient step. Widely used for the NBN street cabinet works - for new installations, upgrades and maintenance for the FTTN roll-out.



CABLE BEARER

ATM426

- This galvanized steel bracket is fixed to manhole walls (in pairs) to support a cable joint.
- Galvanised to ensure a long service life in a hostile environment.
- Provided is a \varnothing 16mm dia hole for a suitable masonry fastener.



ABC CABLE PIERCING TOOL

ATM-PPI514

- Up to 150mm²



ABN 44 071 568 771

"A-Z Product Solutions for Trade and Industry"

sales@all-trades.com.au

www.all-trades.com.au



SIEMENS 2000 TEST LEAD ADAPTOR

ATM-CZ23003

- Suits Quickswitch Handle

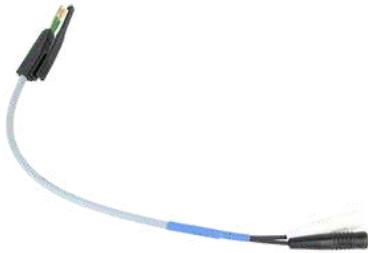

R&M MADISON TEST LEADS FOR CMUX 2 POLE

MADMTVS10/201

- Suits CMUX 2 Pole



LEAD SET W/CROC CLIPS

ATM-SEW-AL-36RYG



Sydney Office
11/5 Hudson Ave
Castle Hill NSW 2154
Ph: 02 8850 2700



Melbourne Office
4/5 Kelleys Rd
Rowville VIC 3178
Ph: 03 9780 4850

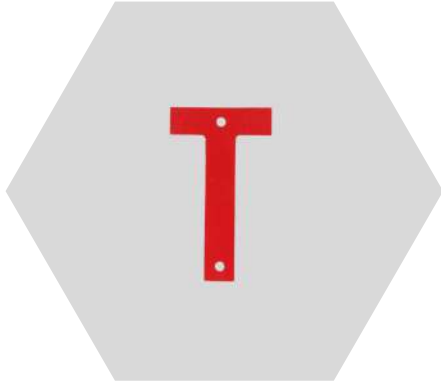

-
-
-
-

"RED T'S"

ATM-REDT

Class 2 Reflective
Aluminium Material
2 holes
100 Pack

MISC.

PILLAR SECURITY SEAL LOCK

SHA-REC102AU

- Aluminium wire lock
- Green colour
- AUSNET LOGO/Barcode
- Secures street pillars

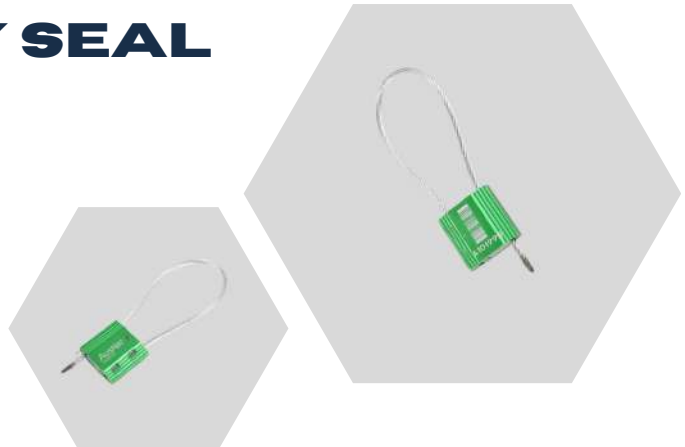

SCREW SELF DRILLING T17

ATM-EZI603



- Has a special long sharp self drilling point with a flute (Type 17) that cuts the timber fibres as it is screwed in.
- Timber fibres are collected in the flute and reduces the potential for splitting.
- The self drilling type 17 point can also pierce light gauge steel up to 0.6mm without predrilling. The head is a hex flanged.
- Easy to install using a 5/16" socket for 10 and 12 gauge or 3/8" socket for 14 gauge or appropriate driver bit in a power tool.
- 1000 IN PACK



ABN 44 071 568 771

"A-Z Product Solutions for Trade and Industry"

sales@all-trades.com.au

www.all-trades.com.au

RIP-A-LABELS

DESCRIPTION

- Each colour suits a different application
- Telstra Approved design
 - CAT V Earth Bond
 - CAT V Feeder Cable
 - CAT V Drop Cable
 - CAT V Power Blocking Device
 - Power Block



TERMINATION JIG

DESCRIPTION

- Designed for Quante Modules



RAYCHEM TELSTRA CABLE END

DESCRIPTION

- Allows for heat shrinking of cut cable ends
- Prevents weather ingress and corrosion of cable internals
- Come in sizes to suit any cable application



75 OHM TERMINATOR/RESISTOR

DESCRIPTION

- Covering unused ports in service taps
- Prevents weather ingress of unused service ports



Sydney Office
11/5 Hudson Ave
Castle Hill NSW 2154
Ph: 02 8850 2700



Melbourne Office
4/5 Kelletts Rd
Rowville VIC 3178
Ph: 03 9780 4850

RG6 CABLE STRIPPER PREP TOOL

DESCRIPTION

- Designed for Industry standard RG6 cable stripping
- Enclosed blade design



FEMALE SPLICE ADAPTOR (3GHZ)

DESCRIPTION

PPC F Female Splice Adapter, 3GHz, Indoor Wall Plate Version, Telstra Approved
100 Included in pack



AMP TRIMMING TOOL (HFC) POTENTIOMETER

DESCRIPTION

- Double-ended moulded plastic trimming tool for single and multi-turn presets, with a protruding blade at one end and a shrouded blade at the other.



RIGHT ANGLE KS → KS ADAPTOR

DESCRIPTION

- Designed for installations where space restrictions require right angle connections between coaxial cables.



KS PORT HOUSING TERMINATOR (HFC)

DESCRIPTION

- Telstra Approved



CABLE FORMING TOOL (SUITS .750 COAX HFC CABLE)

DESCRIPTION

- Suits .75 COAX HFC Cable





TRIDON UNI BAND HOSE CLAMP

UTIH3016M-30

- Compatible with Clamp Bandit Tool

MISC.



TELSTRA TAG ID

ATM97/104

- 65mm x 35mm
- 100p in pack



MONARCH CANVAS DROP SHEET

ATM-DS-101001

- 100% leak proof material
- Ideal for small size rooms
- Finished hems & seams - no fraying
- Super absorbent material
- Double layer construction - canvas with plastic backing



ABN 44 071 568 771

"A-Z Product Solutions for Trade and Industry"

sales@all-trades.com.au

www.all-trades.com.au

RIP-A-LABELS

DESCRIPTION

- Each colour suits a different application
- Telstra Approved design
 - CAT V Earth Bond
 - CAT V Feeder Cable
 - CAT V Drop Cable
 - CAT V Power Blocking Device
 - Power Block



TERMINATION JIG

DESCRIPTION

- Designed for Quante Modules



RAYCHEM TELSTRA CABLE END

DESCRIPTION

- Allows for heat shrinking of cut cable ends
- Prevents weather ingress and corrosion of cable internals
- Come in sizes to suit any cable application



75 OHM TERMINATOR/RESISTOR

DESCRIPTION

- Covering unused ports in service taps
- Prevents weather ingress of unused service ports





ABN 44 071 568 771

"A-Z Product Solutions for Trade and Industry"

sales@all-trades.com.au

www.all-trades.com.au

RIP-A-LABELS

DESCRIPTION

- Each colour suits a different application
- Telstra Approved design
 - CAT V Earth Bond
 - CAT V Feeder Cable
 - CAT V Drop Cable
 - CAT V Power Blocking Device
 - Power Block



TERMINATION JIG

DESCRIPTION

- Designed for Quante Modules



RAYCHEM TELSTRA CABLE END

DESCRIPTION

- Allows for heat shrinking of cut cable ends
- Prevents weather ingress and corrosion of cable internals
- Come in sizes to suit any cable application



75 OHM TERMINATOR/RESISTOR

DESCRIPTION

- Covering unused ports in service taps
- Prevents weather ingress of unused service ports



Sydney Office
11/5 Hudson Ave
Castle Hill NSW 2154
Ph: 02 8850 2700



Melbourne Office
4/5 Kelletts Rd
Rowville VIC 3178
Ph: 03 9780 4850

TUCSON TC-88

DESCRIPTION

TC-88 Optical Fibre Fusion Splicer is a great value fusion machine with accurate operation.

FEATURES

- 4.8-inch LCD Colour Screen
- 7 second fast splicing
- 25 second fast heating
- Titanium Alloy Construction
- SM, MM, DS and NZDS Fibre Applications

Model Number	TC-88
Applicable fiber	SM MM DS and NZDS (Non-Zero Dispersion Shifted Fiber)
Actual average loss	0.02dB(SM) 0.01dB(MM) 0.04dB(DS) 0.04dB(NZDS)
Splicing Time	7s
Heating Time	25s
Applicable fiber diameter	Cladding diameter of 125um; coating diameter 250-900um
Display	4.3 inches LCD colour screen
Maximum storage	5000 set of the latest record storage
Connection time	9s
Dimensions	150mmx130mmx126mm
Weight	1.89Kg



TUCSON



ABN 44 071 568 771

"A-Z Product Solutions for Trade and Industry"

sales@all-trades.com.au

www.all-trades.com.au

TUCSON TC-290E

DESCRIPTION

TC-290 series optical time domain reflectometer is a new generation of portable and intelligent measuring.

FEATURES

- 5.8-inch colour touch screen, key/touch dual operation.
- Standby time as long as 20 hours.
- SM & MM Fibre Testing Capabilities
- 1310nm/1550nm/1625nm Wavelengths
- 37dB/35dB/35dB Dynamic Range
- OTDR
- Stable Laser Source
- Visual Fault Locator
- Optical Power Meter & Loss Test



TUCSON



Sydney Office
11/5 Hudson Ave
Castle Hill NSW 2154
Ph: 02 8850 2700



Melbourne Office
4/5 Kelleys Rd
Rowville VIC 3178
Ph: 03 9780 4850



ABN 44 071 568 771

"A-Z Product Solutions for Trade and Industry"

sales@all-trades.com.au

www.all-trades.com.au

TUCSON TC400B

DESCRIPTION

TC-400B Kit can eliminate the contamination which caused the fibre link failure. This kit contains one-click cleaners and there is no training required. The kit also supports all fibre connector types.

CONTENTS

- 1x Fibre Cleaning Pen for 1.25mm connector
- 1x Fibre Cleaning Pen for 2.5mm connector
- 1x Fibre Cleaning Pen for MPO/MTP
- 1x Fibre cleaning cassette w/ Replacement Reel
- 1x (Box) KimTech wipes
- 10x 1.25mm cleaning swabs
- 10x 2.5mm cleaning swabs
- 1x Carrying Bag



Sydney Office
11/5 Hudson Ave
Castle Hill NSW 2154
Ph: 02 8850 2700



Melbourne Office
4/5 Kelleys Rd
Rowville VIC 3178
Ph: 03 9780 4850

EARTH TESTING REEL

DESCRIPTION

This non-contact AC tester is so popular in Australia that it is onboard most fire and rescue vehicles. It is paramount to the safety of rescue personnel where live voltage may pose a threat and impede rescue operations.

FEATURES

- Green/yellow double insulated 130 strand 6 Amp cable lead
- Cable resists kinking & winds easily
- On PBT engineered polymer reel
- Stackable Banana Plug for multiple connections at service end
- Stainless steel construction
- Auger for easy driving
- Cable length: 20m



EFO EARTH TESTING REEL

DESCRIPTION

The New EFO Independent Earth Trailing Lead sets a new standard of quality and safety, combining several innovative and functional features.

FEATURES

- 20m Insulated Independent Earth Trailing Lead
- 1000V Insulated Handle to eliminate the requirement to cover the spike with an insulating mat
- 20m of green flexible 1.0mm Cable 0.6/1kV
- Adjustable drag system without the use of tools
- Option for direct connection via 4mm Banana plug
- Brass Bushing for extra Low Resistance Connectivity
- Stackable Banana Plug for multiple connections at service end
- Stainless steel construction
- Auger for easy driving
- Cable length: 20m



EFO[®]
Electrical Factory Outlet
Pty Ltd

EFO EARTH TRAILING LEAD

DESCRIPTION

The EFO 50M Compact Earth Trailing Lead connects directly to most brands of test equipment with 4mm banana terminals. Its patented design allows for super fast retrieval. Loaded with 50 meters of green tinned flexible 1.5mm Cable rated at 0.6/1kV. It is also supplied with a 1100mm test lead for meter or accessory connection. Furthermore the cable is dual colour Green/White, to indicate any damage.

FEATURES

- Dual Drum technology for super efficient friction free winding.
- 50 meters of green tinned flexible 1.5mm Cable 0.6/1kV.
- Dual colour cable to indicate damage Green/White.
- Stackable Banana Plug for multiple connections at service end.
- Compact construction.

Included Accessories

- 1 X Large Alligator clip.
- Green Accessory lead 1100mm.





ABN 44 071 568 771

"A-Z Product Solutions for Trade and Industry"

sales@all-trades.com.au

www.all-trades.com.au



COVER LINE

BAL-LSC225

- High quality, light weight, reliable and durable
- UV Stabilised - maximum use 650V
- Complies with and marked to AS4202 Class 2

ELECTRICAL

FLUKE PRV240FS PROVING UNIT

ATM-PRV240FS

- Prove operation of FieldSense function on T6 electrical testers
- Reduce risk of shock and arc flash by validating tool operation
- Source both AC and DC steady-state voltage (240 V AC/DC)



HIOKI VOLTAGE DETECTOR 3481

POW-33481-20

- Non-contact detection of AC voltage from 40 V to 600 V with bright LED light
- Pen-style, compact detector with pocket clip'
- Both visual and audible voltage detection indication
- Meets safety standards for CAT IV 600 V environments

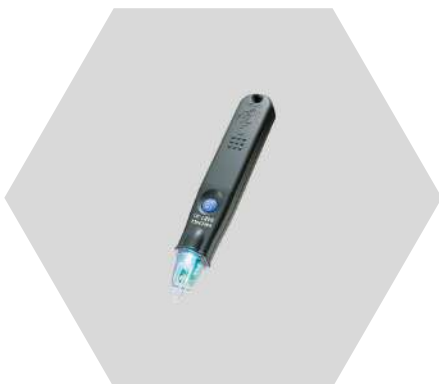

Sydney Office
11/5 Hudson Ave
Castle Hill NSW 2154
Ph: 02 8850 2700



Melbourne Office
4/5 Kelletts Rd
Rowville VIC 3178
Ph: 03 9780 4850

FLUKE VOLT PEN

FLU-1AC-2

DESCRIPTION

The next generation VoltAlert™ AC voltage testers from Fluke are easy to use—just touch the tip to a terminal strip, outlet, or cord. When the tip glows red and the unit beeps, you know there's voltage in the line. This allows electricians, maintenance, service and safety personnel to quickly test for energized circuits and defective grounds.

FEATURES

- Voltage detection range for wide application use - 90 V to 1000 V AC or 200 V to 1000 V AC
- Continuous self-test
- Audible/Silent mode for added convenience
- Detector tip style
 - Blade or round
- Light Source
 - High intensity RED LED
- Safety Rating
 - 1000v CAT IV
- IP40 Certified
- Operating temperature range
 - -10c to 50c
- 2 x AAA Batteries included



HAYCO PHASE SEQUENCE TESTER

DESCRIPTION

- Digital phase rotation tester with 'live' line and two way rotation indication
- Plug in standard instrument test leads
- No moving mechanical parts
- Compact and light



HAYCO VOLTAGE TESTER NEON

DESCRIPTION

- 3 Neon Lamps included in the unit
 - 110v
 - 240v
 - 415v
- Curly Cord
- Flexiprobe System with a short pointer
- 4mm banana supplied as standard



HAIRDRYER LOAD TESTER (1200W) (FLEXIPROBE)

DESCRIPTION

- Hand Held 5A load for meter rotation testing
- 5A fused
- Curly Cord
- Flexiprobe system with two short pointers supplied standard



HAYCO VOLTAGE INDICATOR MULTI CHECK

DESCRIPTION

- 6v-415v AC/DC indication and self check buzzer
- Bright LEDs for daylight operation
- Curly Cord
- 9v Battery Supplied
- Flexiprobe System with a short pointer and 4mm male banana supplied standard





ABN 44 071 568 771

"A-Z Product Solutions for Trade and Industry"

sales@all-trades.com.au

www.all-trades.com.au



COVER LINE

BAL-LSC225

- High quality, light weight, reliable and durable
- UV Stabilised - maximum use 650V
- Complies with and marked to AS4202 Class 2

ELECTRICAL

FLUKE PRV240FS PROVING UNIT

ATM-PRV240FS

- Prove operation of FieldSense function on T6 electrical testers
- Reduce risk of shock and arc flash by validating tool operation
- Source both AC and DC steady-state voltage (240 V AC/DC)



HIOKI VOLTAGE DETECTOR 3481

POW-33481-20

- Non-contact detection of AC voltage from 40 V to 600 V with bright LED light
- Pen-style, compact detector with pocket clip'
- Both visual and audible voltage detection indication
- Meets safety standards for CAT IV 600 V environments

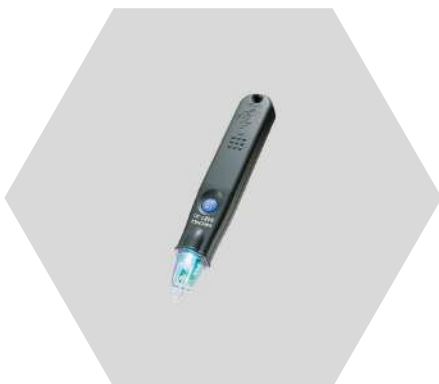

Sydney Office
11/5 Hudson Ave
Castle Hill NSW 2154
Ph: 02 8850 2700



Melbourne Office
4/5 Kelletts Rd
Rowville VIC 3178
Ph: 03 9780 4850

KT170AU VOLTAGE AND CONTINUITY TESTER

FEATURES

- AC and DC voltage tests up to 690V with LED
- Comply with the latest standards IEC 61243 and IEC 61010
- Novel design
- Large and bright LEDs: Values are visible in the dark place Ergonomic design fits in the hand
- Two functions are available in one model
- "Measurement without battery" and "SelfTest (all LED on)"
- Test leads withstand harsh environments at low temperature
- Penlight (white LED)
- Auto-power ON/OFF
- Variable test tips, f2mm or f4mm
- Probe protection cover can store the attachment of caps
- IP65 (IEC 60529)



25M EXTENSION LEAD

ATM-UR24025T

- 25 Meter Cable Length
- 15 AMP Lead
- 10 AMP Plug
- Shielded Socket



4 X OUTLET RCD

ATM-PB94

- Portable Power Block 4 outlet with individual switches
- Rating 240 volt, 10 amp 2400 watt
- In-built residual current device (RCD) safety switch for protection against electric shock (AU)
- Overload protected

INDEPENDENT EARTH REEL W/SPIKE

ATM-ETL20SS

- 1000V insulated handle covering a strong stainless steel rod to eliminate a requirement in some regions to cover the spike.
- The tapered auger assists with easy driving into the variety of soil densities

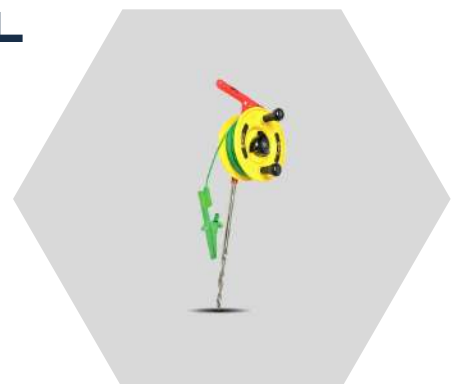

25M EXTENSION LEAD

ATM-UR24025T

- 25 Meter Cable Length
- 15 AMP Lead
- 10 AMP Plug
- Shielded Socket



4 X OUTLET RCD

ATM-PB94

- Portable Power Block 4 outlet with individual switches
- Rating 240 volt, 10 amp 2400 watt
- In-built residual current device (RCD) safety switch for protection against electric shock (AU)
- Overload protected

INDEPENDENT EARTH REEL W/SPIKE

ATM-ETL20SS

- 1000V insulated handle covering a strong stainless steel rod to eliminate a requirement in some regions to cover the spike.
- The tapered auger assists with easy driving into the variety of soil densities

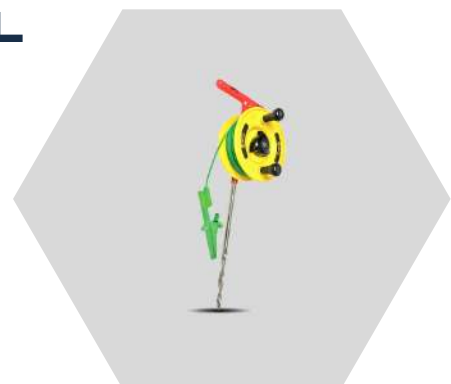



F PORT TERMINATOR TOOL

PHIC165.5



ALL TRADES ALLIGATOR CLIP

ATM-HFPD

- 32mm Max Diameter
- Screw Base



KS PORT TEST PROBE

PHIC.SV05

- Power Blocked
- 20dB
- 1GHz



ABN 44 071 568 771

"A-Z Product Solutions for Trade and Industry"

sales@all-trades.com.au

www.all-trades.com.au

ALMINOX ELECTRICAL JOINTING COMPOUND

DESCRIPTION

Contains sharp, conductive zinc granules suspended in a viscous petroleum base. Under pressure these granules make high pressure contact points with the parent metal to effect a sound electrical connection

FEATURES

- Provides excellent outdoor weathering protection.
- Drop point 188 degree celcius.
- Alminox is distinctive grey in colour.



ELECTRICAL TESTING



Sydney Office
11/5 Hudson Ave
Castle Hill NSW 2154
Ph: 02 8850 2700



Melbourne Office
4/5 Kelleys Rd
Rowville VIC 3178
Ph: 03 9780 4850

CABAC POWER POINT TESTER

DESCRIPTION

A handy low-cost unit that tests a power outlet for polarity, earth connection, incorrect wiring and tests earth leakage circuit breakers.

FEATURES

- Low cost for a big result
- Very simple and easy to use
- Rugged and compact design
- Identifies six wiring conditions
- Integral plug fits straight into the socket
- Push button RCD trip test

INSTRUCTIONS

- To use the unit, simply plug in and compare the neon lights on the front panel with the diagram on the front of the instrument, and it will test the wiring on the power point. To test an earth leakage circuit breaker, first check the wiring as above, then turn the rotary switch to the mA range. To trip the RCD press the test button.



Feature	Range
Voltage Range	230V±10%
Test Conditions	Correct, Active/Neutral Reverse Active/Earth Reverse, No Neutral Live Earth, No Earth No Active
ELCB Test	30mA Trip 10, 15, 20, 25, 30, 35mA
Quiescent Current	1.75mA

CABAC T2720 DIGITAL 3 WIRE EARTH TESTER

DESCRIPTION

The T2720 is a professional instrument that is rugged and o-ring sealed with built-in protection for outdoor use. The instrument is suitable for testing of single earth electrodes such as lightning conductors and other small earthing systems. Continuity of conductors and conduit coupling can also be measured. There is an option to make two terminal measurements, but with reduced accuracy.

FEATURES

- $3\frac{1}{2}$ digit 1999 count LCD
- LED indication for correct electrode range
- Measures to 0.01Ω
- Auto-power 'off'
- Data hold
- Two or three terminal measurement
- Measures earth voltage to 200V
- Open loop indication
- Low battery indication
- O-ring sealed case
- Over voltage protection
- Colour coded test leads
- Crowbar protected



Feature	Range	Accuracy
Earth Resistance	0 to 19.99 Ω steps of 0.01 Ω	2.0% \pm 2
	0 to 199.9 Ω steps of 0.1 Ω	or \pm 0.1 Ω
	0 to 1999 Ω steps of 1 Ω	which ever is greater
Earth Voltage AC	0 to 199.9V (sine 40 to 500 Hz)	
Test Current Output	2mA @ 820 Hz	
Voltage Output	0 to 80V	





CATU APPLICATION HEAD PLATFORM

RNJ-MT630C

- Made of copper aluminium alloy, this clamp dispenser allows attachment of up to 3 of CATU's clamps in order to hook them onto various electrical applications.

ALL TRADES PILLAR SPANNER

VAN-PS



- Comes with 21mm & 26mm swivel socket attachment

ALL TRADES 65MM POINTER (W/SCREW BASE)

ATM-HFPB





ABN 44 071 568 771

"A-Z Product Solutions for Trade and Industry"

sales@all-trades.com.au

www.all-trades.com.au



NST TEST LEADS (STANDARD CLIP)

ATM-HPTL-HFPBED

COMMS EQUIPMENT



CZ1000 TESTER LEADS F SET

ATM-1302



RG11 HEATSHRINK TUBE

PHIH5.8

- 50 pack



Sydney Office
11/5 Hudson Ave
Castle Hill NSW 2154
Ph: 02 8850 2700



Melbourne Office
4/5 Kelleys Rd
Rowville VIC 3178
Ph: 03 9780 4850



ABN 44 071 568 771

"A-Z Product Solutions for Trade and Industry"

sales@all-trades.com.au

www.all-trades.com.au

DESMO CAT IV SINGLE PHASE LOAD TESTER

FEATURES

- Voltage: 240 – 250V max. 1Ø
- Load: 1100W – 4.5amp.
- Internal Fusing: 7amp.
- Safety Rating: Cat IV 600V – Cat III 1000V.
- Compliant to: AS: 61010.1: 2003.
- Weight: 420gm.
- Leads: Silicon with internal white wear indicator layer.
- Test Probes: Cat III 1000V.
- Motor: 1100W with thermal cut-out.
- Grills: Black Nylon 15% Glass Filled.
- Cable Grommet: TPE 90A Shore.
- Body: PC-ABS Fire Retardant – spark finish.
- Hook: Polished 316 S/S that allows hands free operation.



ELECTRICAL TESTING



Sydney Office
11/5 Hudson Ave
Castle Hill NSW 2154
Ph: 02 8850 2700



Melbourne Office
4/5 Kelleys Rd
Rowville VIC 3178
Ph: 03 9780 4850

DEWAR NST V2

NEUTRAL SUPPLY TESTER

FEATURES

- Microprocessor controlled for highest accuracy & reliability
- Testing carried out over 4 Full 50Hz cycles
- Easy to read 2 line LCD for results
- Auto lock out for instrument protection if internal reference resistor overheats during repeated testing
- Withstands accidental connection across 3 phases at 415V
- High strength plastic enclosure with shatterproof decal that withstands 6M drop
- Optional Bluetooth downloading capability
- Optional certified version IP67 case
- Size— 11cm W, 18.5cm H, 4.5cm D, 431.5g



TOOLS & ACCESSORIES

Requirement	M1120 (VIC/SA/NT/QLD/TAS)	M1121 (NSW/ACT)	M1122 (WA)	M1123 (NEW ZEALAND)
Input Operating Voltage	150 to 300 VAC RMS measured between any combination of the Active, Neutral and Earth terminals	150 to 300 VAC RMS measured between any combination of the Active, Neutral and Earth terminals	150 to 300 VAC RMS measured between any combination of the Active, Neutral and Earth terminals	150 to 300 VAC RMS measured between any combination of the Active, Neutral and Earth terminals
Input Frequency	45 to 65 Hz sinusoidal	45 to 65 Hz sinusoidal	45 to 65 Hz sinusoidal	45 to 65 Hz sinusoidal
Quiescent Current	Less than 30mA @ 240 VAC RMS nominal	Less than 30mA @ 240 VAC RMS nominal	Less than 30mA @ 240 VAC RMS nominal	Less than 30mA @ 240 VAC RMS nominal
Test Current	8A ±5% @ 240 VAC RMS Active to Neutral for four full 50 Hz mains power cycles	8A ±5% @ 240 VAC RMS Active to Neutral for four full 50 Hz mains power cycles	8A ±5% @ 240 VAC RMS Active to Neutral for four full 50 Hz mains power cycles	8A ±5% @ 240 VAC RMS Active to Neutral for four full 50 Hz mains power cycles
Active to Neutral Pass Voltage	205 to 264 VAC RMS	205 to 264 VAC RMS	225 to 264 VAC RMS	218 to 244 VAC RMS
Maximum Neutral to Earth Voltage	5.25 VAC RMS ±5%	10 VAC RMS ±5%	5.25 VAC RMS ±5%	5.25 VAC RMS ±5%
Maximum Active to Neutral Impedance	1Ω ±5% maximum	1Ω ±5% maximum	1Ω ±5% maximum	1Ω ±5% maximum
Maximum Earth Connection Impedance	10kΩ ±5% maximum	11kΩ ±5% maximum	10kΩ ±5% maximum	10kΩ ±5% maximum
Maximum Relative Humidity	80% maximum, non-condensing	80% maximum, non-condensing	80% maximum, non-condensing	80% maximum, non-condensing



MODIEWARK FIRE AND RESCUE AC30

DESCRIPTION

This non-contact AC tester is so popular in Australia that it is onboard most fire and rescue vehicles. It is paramount to the safety of rescue personnel where live voltage may pose a threat and impede rescue operations.

FEATURES

- Audio indicator
- Visual indicator
- Transistor circuit verification
- Identifies live wires behind walls
- Tracing live cable runs
- Self Test Function (designed as an independent circuit that produces an AC signal that the detection circuit can pick up, ensures correct tester is working correctly)



MODIEWARK NON-CONTACT VOLTAGE TESTER

DESCRIPTION

The Modiewark AC has two main functions, firstly as a proximity device to determine live or dead situations and then as a touch device to verify the tester has physically reached the AC field around designated mains under test.

FEATURES

- Identifying live conductors
- Fault finding in flexible cables
- Checking equipment grounding
- Neon lighting servicing
- Tracking live wires
- Phasing conductors
- High frequency radiation detection



Voltage sending range	50V AC to 750kV AC
Light source	Three High Intensity LEDs
Sound source	Electromagnetic piezo 85 dB @ 5cm (1.9")
Operating temperature	-40 to 65c (-40 to 149F)
IP range	IP 63
Weight	900g (without batteries)
Dimensions	Length: 230mm Width: 65.85mm (9") Cap diameter 90mm (3.5")





ABN 44 071 568 771

"A-Z Product Solutions for Trade and Industry"

sales@all-trades.com.au

www.all-trades.com.au



NST TEST LEADS (STANDARD CLIP)

ATM-HPTL-HFPBED

COMMS EQUIPMENT



CZ1000 TESTER LEADS F SET

ATM-1302



RG11 HEATSHRINK TUBE

PHIH5.8

- 50 pack



Sydney Office
11/5 Hudson Ave
Castle Hill NSW 2154
Ph: 02 8850 2700



Melbourne Office
4/5 Kelleys Rd
Rowville VIC 3178
Ph: 03 9780 4850



CST750 INSERT REPLACEMENT

PHIC163.6



PHASE SEQUENCE TESTER EXTENSION LEADS (1.2M)

ATM-HMM-HFPM-12



KS PORT TEST PROBE

PHIC.SV05

- Power Blocked
- 20dB
- 1GHz

AMP TRIMMING TOOL (HFC) POTENTIOMETER

DESCRIPTION

- Double-ended moulded plastic trimming tool for single and multi-turn presets, with a protruding blade at one end and a shrouded blade at the other.



RIGHT ANGLE KS → KS ADAPTOR

DESCRIPTION

- Designed for installations where space restrictions require right angle connections between coaxial cables.



KS PORT HOUSING TERMINATOR (HFC)

DESCRIPTION

- Telstra Approved



CABLE FORMING TOOL (SUITS .750 COAX HFC CABLE)

DESCRIPTION

- Suits .75 COAX HFC Cable



SEW 890PR PHASE ROTATION TESTER

DESCRIPTION

- The SEW 890PR Non-Contact Three Phase Sequence and Rotation Tester allows the verification of phase sequence without contacting live terminals
- Using non-contact inductive clips that allows the user to simply clip the sensors to the outside of each cable without removing the insulation.

FEATURES

- The 890 PR is a Non-Contact phase detector with flashing LEDs and a beeping buzzer to show the detection of AC 3-phase sequence.
- Two functions in one unit : open phase & phase sequence detection.
- Convenient brightness switch to make the indication visible in dim areas or sunlight.
- Back cover magnets which attach the instrument to the AC distribution panel offer easy measurement.
- 3-Phase AC 70 to 1000V is fitted for detection.
- Conductor size: 1~35mm
- Detect frequency range is from 45 to 65Hz.





ABN 44 071 568 771

"A-Z Product Solutions for Trade and Industry"

sales@all-trades.com.au

www.all-trades.com.au

KYORITSU 2056R CLAMP METER

FEATURES

- Designed to meet international safety standard IEC 61010-1 CAT IV 600V.
- CAT IV Clamp Meters can measure the Voltage and Current in both every low and high power circuits.
- Very useful for power distribution companies, power utilities and maintenance fields.
- True RMS enables an accurate measurement.
- 600v Input Protection
- Sleep function to save battery life
- With Continuity & Diode check Function



ELECTRICAL TESTING



Sydney Office
11/5 Hudson Ave
Castle Hill NSW 2154
Ph: 02 8850 2700



Melbourne Office
4/5 Kelleys Rd
Rowville VIC 3178
Ph: 03 9780 4850

KYORITSU 3132A 1000V INSULATION & CONTINUITY TESTER

DESCRIPTION

The Kyoritsu insulation and continuity tester has a measuring range of 100M Ω , 200M Ω and 400M Ω . The testing voltage of this tester ranges between 250V and 1000V. This tester is powered by 6AA batteries.

FEATURES

- Automatic discharge of circuit capacitance (any charge stored in the circuit under test will be automatically discharged after testing)
- Dust and drip proof construction
- Easy to read scale means less confusing digital readings
- Live circuit warning buzzer and neon lamp
- Shock resistant new case material
- Small and light weight
- Zero out your trailing lead resistance so you don't need to subtract the resistance of your trailing earth lead every time you test
- Voltage: 250V - 1000V
- Rated test current at the maximum resistance: 1mA
- Short circuit current on continuity testing: 200mA
- Batteries: 6AA





ABN 44 071 568 771

"A-Z Product Solutions for Trade and Industry"

sales@all-trades.com.au

www.all-trades.com.au



SIEMENS 2000 TEST LEAD ADAPTOR

ATM-CZ23003

- Suits Quickswitch Handle

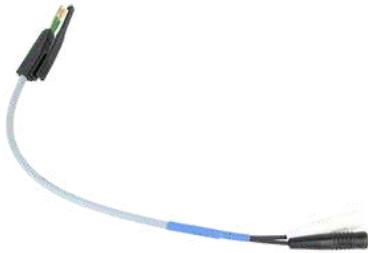

R&M MADISON TEST LEADS FOR CMUX 2 POLE

MADMTVS10/201

- Suits CMUX 2 Pole



LEAD SET W/CROC CLIPS

ATM-SEW-AL-36RYG



Sydney Office
11/5 Hudson Ave
Castle Hill NSW 2154
Ph: 02 8850 2700



Melbourne Office
4/5 Kelleys Rd
Rowville VIC 3178
Ph: 03 9780 4850



CABAC HAND HELD CRIMPER (<25MM²)

CABK28

- Hand Held
- 6-25mm² Capacity
- Copper Lugs
- Crimp Type = 'W'



10-1000V DUAL RANGE VOLTAGE DETECTOR (TOOL ONLY)

ATC-2203-20

- Automatically differentiates 10-49V and 50-1000V.
- Different colours identify voltage range.
- Built-in LED work light.
- Auto-off.
- AAA Battery Included

IRWIN VISE GRIPS

ATM-T11T



- Provides comfort, control and less hand fatigue
- Jaw mechanism provides 3X more gripping power
- 2x Longer life: High grade alloy steel is heat treated for maximum toughness and durability

TUCSON TC-88

DESCRIPTION

TC-88 Optical Fibre Fusion Splicer is a great value fusion machine with accurate operation.

FEATURES

- 4.8-inch LCD Colour Screen
- 7 second fast splicing
- 25 second fast heating
- Titanium Alloy Construction
- SM, MM, DS and NZDS Fibre Applications

Model Number	TC-88
Applicable fiber	SM MM DS and NZDS (Non-Zero Dispersion Shifted Fiber)
Actual average loss	0.02dB(SM) 0.01dB(MM) 0.04dB(DS) 0.04dB(NZDS)
Splicing Time	7s
Heating Time	25s
Applicable fiber diameter	Cladding diameter of 125um; coating diameter 250-900um
Display	4.3 inches LCD colour screen
Maximum storage	5000 set of the latest record storage
Connection time	9s
Dimensions	150mmx130mmx126mm
Weight	1.89Kg



TUCSON



PROMAC[®] generators built to get dirty.

TOUGH >>> POWERFUL >>> READY

tradie generators

READY to work!



2.8KVA tradie generator Model: GT028

- HP 6.5
- From 68 dB(A) @ 7m
- Recoil Starting System
- Max Watts 2300W, Rated Watts 2000W
- Weight: 45kg
- Fuel Tank Capacity: 18L
- Run Time: 15 Hours @ 50% load
- Dimensions: 59L x 43W x 48cmH
- IP66 Rated RCD & Waterproof Outlets
- 1 Power Outlet- 15amp
- Wheel & Handle Kit Included
- High Quality Clean Power
- Sine Wave Alternators
- Automatic Voltage Regulator
- 12 Volt outlet



4KVA tradie generator Model: GT040

- HP 7.0
- From 68 dB(A) @ 7m
- Recoil Starting System
- Max Watts 3200W, Rated Watts 2900W
- Weight: 48kg
- Fuel Tank Capacity: 18L
- Run Time: 17 hrs @ 50% load
- Dimensions: 59L x 43W x 48cmH
- IP66 Rated RCD & Waterproof Outlets
- 1 Power Outlet- 15amp
- Wheel & Handle Kit Included
- High Quality Clean Power
- Sine Wave Alternators
- Automatic Voltage Regulator
- 12 Volt outlet



6.8KVA electric start tradie generator Model: GT068E

- HP 13
- From 72 dB(A) @ 7m
- Recoil/Electric Starting System
- Max Watts 5500W, Rated Watts 5000W
- Weight: 88kg
- Fuel Tank Capacity: 25L
- Run Time: 13 hrs @ 50% load
- Dimensions: 68L x 54W x 55cmH
- Lifting hook available Model #GTLHL
- IP66 Rated RCD & Waterproof Outlets
- 2 Power Outlet- 15amp
- Battery, Wheel & Handle Kit Included
- High Quality Clean Power
- Sine Wave Alternators
- Automatic Voltage Regulator
- 12 Volt outlet



8.1KVA electric start tradie generator Model: GT081E

- HP 15
- From 72 dB(A) @ 7m
- Recoil/Electric Starting System
- Max Watts 6500W, Rated Watts 6000W
- Weight: 90kg
- Fuel Tank Capacity: 25L
- Run Time: 11.3 hrs @ 50% load
- Dimensions: 68L x 54W x 55cmH
- Lifting hook available Model #GTLHL
- IP66 Rated RCD & Waterproof Outlets
- 2 Power Outlet- 15amp
- Battery, Wheel & Handle Kit Included
- High Quality Clean Power
- Sine Wave Alternators
- Automatic Voltage Regulator
- 12 Volt outlet



12KVA electric start tradie generator Model: GT12E

- HP 20
- From 76 dB(A) @ 7m
- Recoil/Electric Starting System
- Max Watts 9500W, Rated Watts 8500W
- Weight: 143kg
- Fuel Tank Capacity: 48L
- Run Time: 20 hrs @ 50% load
- Dimensions: 80L x 62W x 65cm H
- Lifting hook available Model #GTLHL
- IP66 Rated RCD & Waterproof Outlets
- 3 Power Outlet- 15amp
- Battery, Wheel & Handle Kit Included
- High Quality Clean Power
- Sine Wave Alternators
- Automatic Voltage Regulator
- 12 Volt outlet
- Hour Meter
- Easy to screw on replaceable oil filter



6.8KVA electric start diesel generator Model: GTD068E

- HP 10
- From 111 dB(A) @ 7m
- Recoil/Electric Starting System
- Max Watts 5500W, Rated Watts 5000W
- Weight: 143kg
- Fuel Tank Capacity: 14.5L
- Run Time: 10 hrs @ 50% load
- Dimensions: 80L x 62W x 65cmH
- Lifting hook available Model #GTLHL
- Diesel engine
- IP66 Rated RCD & Waterproof Outlets
- 2 Power Outlet- 15amp
- Battery, Wheel & Handle Kit Included
- High Quality Clean Power
- Sine Wave Alternators
- Automatic Voltage Regulator
- 12 Volt outlet
- Low oil alert
- Easily accessed oil filter

3 YEAR WARRANTY
on torini engines • 4 year domestic

POWERED BY **TORINI ENGINES**

Diesel

inverter generators

Extremely quiet, powerful and portable!

Promac Inverter Generators are the perfect unit for all your camping and recreational needs. The microprocessor controlled inverter produces a high precision, pure sine wave power output. Suitable to use with sensitive electronics such as: laptops, mobile phones, computers, refrigerators, air conditioners and microwaves making it ideal for backup power in any situation. The 3.3KVA Inverter Generator also has >1.5% THV (Total Harmonic Distortion). When compared on the market you will find the 3.3KVA Promac Inverter to be the quietest, lightest and most powerful in it's class!

PATENTED FEATURES:

- Engine with big volume muffler to increase fuel efficiency and reduce noise
- Permanent magnet inverter generator with ESC intelligently controls rpm to reduce noise and fuel consumption
- 3 way cooling system to lower running temp and extend engine life
- Exhaust gas circulation- exhaust gas passes through 2 cavities for double oil separation, decreases oil consumption and extends engine life
- Single cylinder, 4 stroke, forced air cooling, OHV engine
- Meets EPA, Proposed Australia Emissions
- Amongst the world's strictest environmental protection standards



3 YEAR WARRANTY
on torini engines • 4 year domestic



2KVA inverter generator Model: GC020I

- HP 3.2
- From 52 dB(A) @ 7m
- Recoil Starting System
- Max Watts 2000W, Rated Watts 1600W
- Weight: 21kg
- Fuel Tank Capacity: 4.1L
- Run Time: 7 Hours @ 50% load
- Dimensions: 52L x 29W x 48cmH
- 1 Power Outlet- 15amp
- Includes parallel connection cable
- 12 Volt outlet
- OHV- 4 stroke reliability
- Engine Smart Control (ESC)
- Includes battery charger



3.3KVA electric start inverter generator Model: GC033IE

- HP 7
- From 50 dB(A) @ 7m
- Recoil/Electric Starting System
- Max Watts 3300W, Rated Watts 3000W
- Weight: 45kg
- Fuel Tank Capacity: 10L
- Run Time: 11 Hours @ 50% load
- Dimensions: 58L x 44W x 51cmH
- 2 Power Outlets- 15amp
- Parallel cable optional for Model GC033IE: PCK33
- 12 Volt outlet
- OHV- 4 stroke reliability
- Engine Smart Control (ESC)
- Includes battery and charger
- Digital Data Meter



extreme power!

GET 2 x THE POWER

2 x 2KVA Inverters using parallel cable
= 3,200w

2 x 3.3KVA Inverters using parallel cable PCK33
= 6,000w

1 x 2KVA + 1 x 3.3KVA Inverters using parallel cable PCK33
= 4,600w

NO LOSS OF POWER.

»»» TOUGH »»» POWERFUL »»» READY »»»

www.promac.com.au



CHOOSING THE RIGHT generator for you!

COMMON FORMULAS:

1KW	=	1000W	1KVA	=	1.4 Amps (single phase)
1KVA	=	800W	WATTS	=	Volts x Amps
1HP	=	750W	AMPS	=	Watts/Volts

GENERAL RULE #1

Compressors and other induction motors (e.g. Fridges, freezers, and air conditioners will require a minimum of 3 times the HP of the motor to the KVA to start. For example, an air conditioner with 1HP motor will require 3KVA every time that motor cycles in.

GENERAL RULE #2

Common Applications - Welders & Compressors:

- 120amp welder or 8CFM compressor requires a min of 5KVA
- 140amp welder or 10CFM compressor requires a min of 6KVA
- 160amp welder or 12CFM compressor requires a min of 7KVA
- 180amp welder or 14CFM compressor requires a min of 8KVA

GENERAL RULE #3

To work out the generator size required, simply add the wattage of all appliances or construction tools likely to be used at the same time. Don't forget to allow for any induction motors.

General guide to appliance ratings:

Appliances	Power Running	Power Start Up
Toaster or Microwave	1000 watts	
Fridge / Freezer	700 watts	2100 watts
TV	200 watts	
Oven	3100 watts	
Coffee Machine	1500 watts	
Kettle	2400 watts	
Vacuum	1600 watts	2600 watts
Fluro Lamp	36 watts	72 watts
Light Bulb 100w	100 watts	
Heater	800 watts	
iPhone charger	12 watts	
Laptop	200 watts	
Air Conditioner - refrigerated	2600 watts	7800 watts
Fan	40 watts	120 watts

Construction Tools	Power Running	Power Start Up
Compressor	1600 watts	4800 watts
Angle Grinder 180mm	1800 watts	3600 watts
Concrete Mixer	1200 watts	3600 watts
Circular Saw	1400 watts	2800 watts
Power Drill	800 watts	1600 watts
Welder 180amp	3300 watts	9900 watts
Pressure Washer	1200 watts	3600 watts

** This example chart above is a guide only. Power demand varies between appliance brands and models, please consult your dealer for more assistance.

Local Dealer:

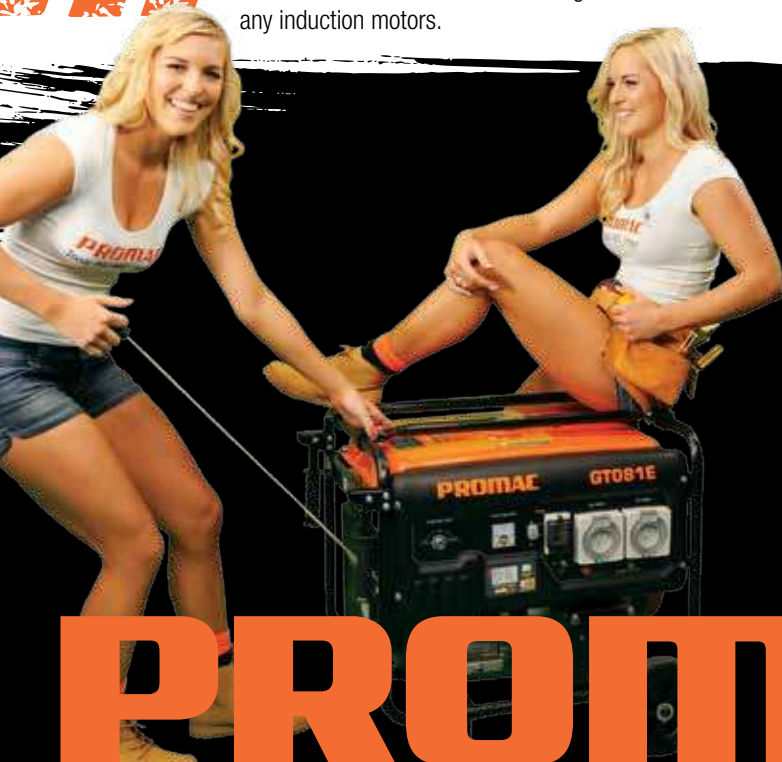

PROMAC®

CONTACT US NOW FOR MORE INFORMATION!

P 1800 773 267 W www.promac.com.au E promac@promac.com.au





ABN 44 071 568 771

"A-Z Product Solutions for Trade and Industry"

sales@all-trades.com.au

www.all-trades.com.au

DURAPATCH

FUNCTIONALITY

Protocol: ISO 15693

Operating Frequency: HF - 13.56MHz

Memory Configuration: 15 Character UID, 896 bits User Memory

- Read/Write Capability

PERFORMANCE

Read Range: Up to 1°

Orientation: Front Face Read

IP Rating: IP68

PHYSICAL

Material: Rubber

Mounting System: Adhesive

OPERATIONAL

Continuous Max Service Temp: 150c

Continuous Min Service Temp: -40c

Water and Ice Proof: Yes

PRODUCT

Weight: 5g

Dimensions: 28mm²

Thickness: 2mm



INFOCHIP



Sydney Office
11/5 Hudson Ave
Castle Hill NSW 2154
Ph: 02 8850 2700



Melbourne Office
4/5 Kelleys Rd
Rowville VIC 3178
Ph: 03 9780 4850



ABN 44 071 568 771

"A-Z Product Solutions for Trade and Industry"

sales@all-trades.com.au

www.all-trades.com.au

DURAPATCH

FUNCTIONALITY

Protocol: ISO 15693

Operating Frequency: HF - 13.56MHz

Memory Configuration: 15 Character UID, 896 bits User Memory

- Read/Write Capability

PERFORMANCE

Read Range: Up to 1°

Orientation: Front Face Read

IP Rating: IP68

PHYSICAL

Material: Rubber

Mounting System: Adhesive

OPERATIONAL

Continuous Max Service Temp: 150c

Continuous Min Service Temp: -40c

Water and Ice Proof: Yes

PRODUCT

Weight: 5g

Dimensions: 28mm²

Thickness: 2mm



INFOCHIP



Sydney Office
11/5 Hudson Ave
Castle Hill NSW 2154
Ph: 02 8850 2700



Melbourne Office
4/5 Kelleys Rd
Rowville VIC 3178
Ph: 03 9780 4850



ABN 44 071 568 771

"A-Z Product Solutions for Trade and Industry"

sales@all-trades.com.au

www.all-trades.com.au

DURAPLUG

CS-DURAPLUG*-HF

FUNCTIONALITY

Protocol: ISO 15693

Operating Frequency: HF - 13.56MHz

Memory Configuration: 16 Character UID, 896 bits User Memory

- Read/Write Capability

PERFORMANCE

Read Range: Up to 1°

Orientation: Front Face Read

IP Rating: IP68

PHYSICAL

Material: PPA + GF30%

Mounting System: Metal-Embeddable, Press Fit

Color: Custom Logo/Colours Available

OPERATIONAL

Continuous Max Service Temp: 100c (Plug6) 125c (Plug8)

Continuous Min Service Temp: -40c

IK Impact Rating: IK10

Water and Ice Proof: Yes

PRODUCT

Weight: .17g (Plug6) .27 (Plug8)

Dimensions: 6mm (Plug6) 8mm (Plug8) (diameter)

Thickness: 2.25mm (Plug6) 3.25mm (Plug8)



INFOCHIP



Sydney Office
11/5 Hudson Ave
Castle Hill NSW 2154
Ph: 02 8850 2700



Melbourne Office
4/5 Kelleys Rd
Rowville VIC 3178
Ph: 03 9780 4850

DURATAB

ICS-DURATAB-HF-001

FUNCTIONALITY

Protocol: ISO 15693

Operating Frequency: HF - 13.56MHz

Memory Configuration: 16 Character UID, 896 bits User Memory

- Read/Write Capability

PERFORMANCE

Read Range: Up to 1°

Orientation: Front Face Read

IP Rating: IP68

PHYSICAL

Material: PC/PBT Alloy with Stainless Steel Frame

Mounting System: Attachment Holes, Hanging

Color: Custom Logo/Colours Available

OPERATIONAL

Continuous Max Service Temp: 125c

Continuous Min Service Temp: -40c

IK Impact Rating: IK10

Water and Ice Proof: Yes

PRODUCT

Weight: 17.7g

Dimensions: 50.8mmx25.4mm

Thickness: 6.35mm



DURAZIP

ICS-DURAZIP-HF-001

FUNCTIONALITY

Protocol: ISO 15693

Operating Frequency: HF - 13.56MHz

Memory Configuration: 16 Character UID, 896 bits User Memory

- Read/Write Capability

PERFORMANCE

Read Range: Up to 1°

Orientation: Two Face Read

IP Rating: IP68

PHYSICAL

Material: PC/PBT

Mounting System: Stainless Steel Cable

Color: Custom Logo/ Colours Available

OPERATIONAL

Continuous Max Service Temp: 125c

Continuous Min Service Temp: -40c

IK Impact Rating: IK10

Water and Ice Proof: Yes

PRODUCT

Weight: 40g

Dimensions: 35.56mm x 30.48mm diameter)

Thickness: 17.78mm



SYNTHETICTAG

ICS-SYNTHLAUNDRY-HF

FUNCTIONALITY

Protocol: ISO 15693

Operating Frequency: HF - 13.56MHz

Memory Configuration: 16 Character UID, 896 bits User Memory

- Read/Write Capability

PERFORMANCE

Read Range: Up to 1°

Orientation: Two Face Read

IP Rating: IP68

PHYSICAL

Material: Plastic

Mounting System: String Thread

Color: Cream

OPERATIONAL

Continuous Max Service Temp: 160c

Continuous Min Service Temp: -40c

IK Impact Rating: IK10

Water and Ice Proof: Yes

PRODUCT

Weight: 1g

Dimensions: 15.24mm (diameter)

Thickness: 2.794mm





ABN 44 071 568 771

"A-Z Product Solutions for Trade and Industry"

sales@all-trades.com.au

www.all-trades.com.au

DATABAND2

ICS-DURABAND2-HF-001

FUNCTIONALITY

Protocol: ISO 15693

Operating Frequency: HF - 13.56MHz

Memory Configuration: 16 Character UID, 896 bits User Memory

- Read/Write Capability

PERFORMANCE

Read Range: Less than 1°

Orientation: Front Face Read

IP Rating: IP68

PHYSICAL

Material: PC/PBT Alloy

Mounting System: : Metal Band

Color: Custom Logo Available

OPERATIONAL

Continuous Max Service Temp: 125c

Continuous Min Service Temp: -40c

Water and Ice Proof: Yes

PRODUCT

Weight: 5g

Dimensions: 38.1 x 19.05mm Diameter

Thickness: 9.652mm



INFOCHIP



Sydney Office
11/5 Hudson Ave
Castle Hill NSW 2154
Ph: 02 8850 2700



Melbourne Office
4/5 Kelleys Rd
Rowville VIC 3178
Ph: 03 9780 4850

DATABANDMICRO+

ICS-DURABANDMICRO-HF-001

FUNCTIONALITY

Protocol: ISO 15693

Operating Frequency: HF - 13.56MHz

Memory Configuration: 16 Character UID, 896 bits User Memory

- Read/Write Capability

PERFORMANCE

Read Range: Up to 0.5°

Orientation: Front Face Read

IP Rating: IP68

PHYSICAL

Material: PC/PBT Alloy

Mounting System: : Metal Band 0.25" wide max. Cable Tie 0.25"

x x 0.055" max; 0.10" Dia Wire Rope max

Color: Custom Logo Available

OPERATIONAL

Continuous Max Service Temp: 125c

Continuous Min Service Temp: -40c

Water and Ice Proof: Yes

PRODUCT

Weight: 1.4g

Dimensions: 22.352 x 12.7mm Diameter

Thickness: 6.35mm





ABN 44 071 568 771

"A-Z Product Solutions for Trade and Industry"

sales@all-trades.com.au

www.all-trades.com.au

DURADISC

ICS-DURADISC-HF-001

FUNCTIONALITY

Protocol: ISO 15693

Operating Frequency: HF - 13.56MHz

Memory Configuration: 16 Character UID, 896 bits User Memory

- Read/Write Capability

PERFORMANCE

Read Range: Up to 1°

Orientation: Front Face Read

IP Rating: IP68

PHYSICAL

Material: PC/PBT Alloy

Mounting System: Extreme-Environment Acrylic Adhesive

Color: Custom Logo Available

OPERATIONAL

Continuous Max Service Temp: 75c

Continuous Min Service Temp: -40c

Water and Ice Proof: Yes

PRODUCT

Weight: 1g

Dimensions: 19.05mm Diameter

Thickness: 5.08mm



INFOCHIP



Sydney Office
11/5 Hudson Ave
Castle Hill NSW 2154
Ph: 02 8850 2700



Melbourne Office
4/5 Kelleys Rd
Rowville VIC 3178
Ph: 03 9780 4850



ABN 44 071 568 771

"A-Z Product Solutions for Trade and Industry"

sales@all-trades.com.au

www.all-trades.com.au

DURADISC

ICS-DURADISC-HF-001

FUNCTIONALITY

Protocol: ISO 15693

Operating Frequency: HF - 13.56MHz

Memory Configuration: 16 Character UID, 896 bits User Memory

- Read/Write Capability

PERFORMANCE

Read Range: Up to 1°

Orientation: Front Face Read

IP Rating: IP68

PHYSICAL

Material: PC/PBT Alloy

Mounting System: Extreme-Environment Acrylic Adhesive

Color: Custom Logo Available

OPERATIONAL

Continuous Max Service Temp: 75c

Continuous Min Service Temp: -40c

Water and Ice Proof: Yes

PRODUCT

Weight: 1g

Dimensions: 19.05mm Diameter

Thickness: 5.08mm



INFOCHIP



Sydney Office
11/5 Hudson Ave
Castle Hill NSW 2154
Ph: 02 8850 2700



Melbourne Office
4/5 Kelleys Rd
Rowville VIC 3178
Ph: 03 9780 4850



NON-CONDUCTIVE
SAFE FOR ELECTRICAL WORK

FIBREGLASS PLATFORM STEP LADDERS PREMIUM RANGE

150KG RATED | AS 1892
LENGTHS .61m - 2.89m

LIGHTWEIGHT

Strongest double hollow step treads

STRENGTH

World's safest fibreglass platform ladders
500kg load tested
Swagelock step connection **50% stronger**

SOLID FOUNDATION

Stronger RHS section rear frame
Strongest foot connection and strongbow base brace system



OPTIONS



SAFETY GATE

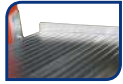

PLATFORM KICKBOARD



CASTOR KIT

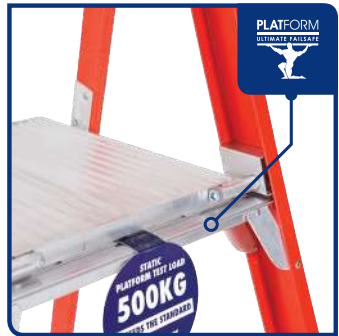

CODE	PLATFORM HEIGHT (m)	WIDTH (mm)	WEIGHT (kg)	TRANSPORT CUBE (m ³)
FPS5-2	.61	580	11	.33
FPS6-3	.88	620	12	.39
FPS7-4	1.17	660	13	.45
FPS8-5	1.45	700	14	.51
FPS9-6	1.74	740	15	.57
FPS10-7	2.02	780	16	.63
FPS11-8	2.30	820	17	.69
FPS13-10	2.89	1050	26	1.22

All measurements are nominal and do not indicate 'exact weights and measures'



PROUDLY AUSTRALIAN MADE

LADaMAX[®]
AUSTRALIA'S LADDER SPECIALIST



www.all-trades.com.au

sales@all-trades.com.au
Ph; 02 8850 2700 NSW
03 9780 4850 VIC



PRODUCT GUIDE

May 2021



AUSTRALIA'S #1 LADDER BRAND
BAILEYLADDERS.COM.AU

THE PUNCHLOCK® ADVANTAGE

AUSTRALIA'S #1 LADDER BRAND

Bailey's Professional range of ladders are manufactured using our Punchlock® construction technology. Combined with our unique double hollow tread design, this gives the distinct advantages of strength, stiffness and durability unmatched by riveted ladders.



PUNCHLOCK® SUPER STRONG

- 66% stronger than conventional riveted type ladders
- Increased strength and durability



DOUBLE HOLLOW TREAD TWIST RESISTANT

- Increased rigidity and stiffness in the ladder frame
- Reduces ladder twisting



TRI-BRACING SUPER STABLE

- Strongest support between tread and stile
- Eliminates catch points



LIGHTWEIGHT DESIGN SUPER LIGHT

- Industrial strength and safety with a lightweight advantage
- Reduces strain and fatigue

All these distinct advantages are engineered into our Professional range of Aluminium and Fibreglass ladders.

DISCOVER THE ADVANTAGE YOURSELF - INVEST IN OUR SUPERIOR PROFESSIONAL RANGE OF LADDERS THAT WILL GIVE YOU YEARS OF SERVICE.

BAILEY PRODUCT GUIDE 2021

CONTENTS

Choosing The Right Ladder



Load/Duty Ratings & Ladder Safety



Single Side Leaning & Double Sided Stepladders

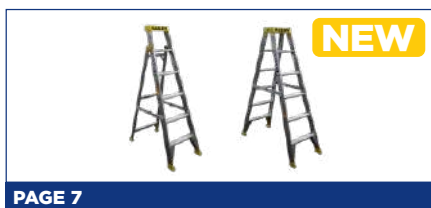

A general purpose stepladder accessed from a single side only or both sides, on a double sided stepladder.

Multi-Purpose Ladders



Highly versatile – can be used as a stepladder and a straight ladder with adjustable heights, or separated into two low-level trestles.

SLS 3 IN 1 Ladders



A revolutionary new design of ladder that can be used as Step Ladder, a Leaning Ladder or a Straight Ladder.

Dual Purpose & Step Extension Ladders



Highly versatile (2 in 1) – converts from a stepladder to a straight ladder.

Extension & Single Ladders



Designed for height access for builders, carpenters, plumbers and serious DIY. Fixed length or height adjustable.

Platform Stepladders



Provides a safe work platform when working at heights. Can be closed for storage.

Safety Steps



A compact access solution where storage space is at a premium

Attic Ladders



Lightweight, aluminium ladders designed to access roof spaces.

Order Pickers & Access Platforms



Used for moderate/frequent use stock picking applications.

Modular Access/ Platform Systems



A versatile platform system that can be configured to your requirements up to a platform height of 1.65m

Mobile Scaffolding



Designed for quick, safe and efficient erection and use at the work site or around the home.

CHOOSING THE RIGHT LADDER

STEP 1 - LADDER SIZE

Choose the correct size of ladder for the job

• 1m = 3 feet approximately

STEPLADDERS		EXTENSION LADDERS		PLATFORMS	
Ladder Size	Max. Reach Height	Ladder Size	Max. Reach Height	Platform Size	Max. Reach Height
2	2.0m	8	5.0m	2	2.6m
3	2.3m	10	6.2m	3	2.9m
4	2.6m	12	7.4m	4	3.2m
5	2.9m	14	8.9m	5	3.5m
6	3.2m	15	9.5m	6	3.75m
7	3.5m	16	10.1m	7	4.0m
8	3.8m	17	10.7m	8	4.3m
10	4.4m	18	11.6m	10	4.9m
12	5.0m	20	12.2m	12	5.5m

STEP 2 - LADDER TYPE

Choose the correct type of ladder for the job



Step Stool



Platform Stepladder



Single Sided Leaning Stepladder



Double Sided Leaning Stepladder



Dual Purpose Stepladder



Single & Extension Ladder



Order Picker & Access Platform



Scaffold

STEP 3 - LADDER MATERIAL

Choose the right construction

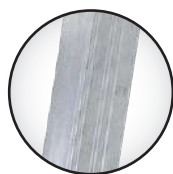

Aluminium:
Lightweight

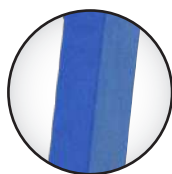

Fibreglass:
Electro - Safe™
(non-conductive)

STEP 4 - LOAD/DUTY RATING

Choose a suitable load and duty rating



Load Rating: The maximum load including the weight of the user, materials and tools which the ladder is intended to carry.

Duty Rating: The rating assigned to a ladder, ie. industrial or domestic, which indicates the service capability of the ladder.

Bailey product selection assistant: <http://baileyladders.com.au/product-selector>

5.1m

GUTTERS	
Single Storey	
2.4m	2.7m
Double Storey	
5.1m	5.7m

EXTERIOR WALLS	
Windows	
2.4m	2.7m

2.7m

CEILINGS	
Light Fittings	
2.4m	2.7m

INTERIOR WALLS	
Wall Hangings	
2.4m	2.7m



LOAD/ DUTY RATINGS IN DETAIL AND LADDER SAFETY

What is a 'load rating'?

The maximum safe working load of the ladder, including the weight of the user tools/equipment and materials they are carrying.

Exceeding the safe working load is dangerous and voids warranties. A minimum load rating of 120kg must be used in all 'workplaces'.

What is a 'duty rating'?

The duty rating is assigned by the manufacturer based on the product's design parameters.

There are two duty ratings: Domestic and Industrial. Only ladders with an 'Industrial' duty rating can be used in any workplace.

Ratings Explained

DOMESTIC 100KG

DOMESTIC

For domestic use in and around the home e.g. cleaning, cupboard access. Must not be used in a workplace. Made to the requirements of Australian Standards AS1892

INDUSTRIAL 135KG

INDUSTRIAL 120KG

INDUSTRIAL

For moderate industrial use. An industrial grade of ladder for trade or serious DIY/handyman. Made to the requirements of Australian Standards AS1892

INDUSTRIAL 225KG W.L.L

INDUSTRIAL 200KG

INDUSTRIAL 170KG

INDUSTRIAL 160KG

INDUSTRIAL 150KG

INDUSTRIAL 140KG

INDUSTRIAL - HEAVY DUTY - PROFESSIONAL

For heavy duty industrial trade/ commercial use by professional contractors, tradespersons, workplaces, serious DIY/handyman. Made to the requirements of Australian Standards AS1892

Ladder Safety and General Principles

- Ladders must be handled with care at all times.
- Observe the manufacturers warnings and instructions.
- Observe closely the area in which you wish to position the ladder and assess for risks (e.g. open door ways, overhead power lines, uneven ground).
- Where a risk is present, remove (or reduced to an acceptable level) the risk, or seek an alternative safe means of access.
- Ladders are designed and built for a specific use. Read the warning labels and never use the ladder that is not recommended by the manufacturer.
- Choose the right type of ladder and the correct height for the task at hand.
- Always inspect the ladder for damage prior to use.
- NEVER USE A LADDER THAT HAS BEEN DAMAGED OR HAS MISSING PARTS.
- Ensure the ladder is free from dirt, water and grease prior to use paying particular attention to the treads/ rungs.
- When using a ladder near a door way, block/lock the door and/or post a guard.
- Do not leave ladders unattended while they are erected in case of children climbing.
- Always wear fully enclosed footwear with slip resistance soles.
- Avoid using ladders in very wet or windy conditions.
- Never use a ladder if you are impaired by drugs, alcohol or sickness.

SINGLE SIDED LEANING & DOUBLE SIDED STEPLADDERS





Multi-function top cap



Multi-function top cap

PROFESSIONAL PUNCHLOCK® SINGLE SIDED LEANING STEPLADDER **NEW**

ALUMINIUM
LIGHTWEIGHT

INDUSTRIAL

150KG

The new Bailey Pro Punchlock® aluminium single sided leaning stepladder gets you close to the worksurface improving job site safety and productivity.

- 150kg load rating and industrial duty rating make it suitable for trade and commercial applications
- The Punchlock® tread design increases torsional rigidity of the overall ladder frame
- Unique top cap allows the ladder to be safely used as a leaning ladder
- The multi-function top cap provides storage for tools
- Anti-slip PVC boots for added stability
- Light weight and strong aluminium construction
- Flat plate tri-bracing increases strength and stability
- Made to Australian Standards AS1892



Product No.	Description	Nominal Size	Nominal Max. Reach Height	EAN Code	Nominal Weight
FS13957	Pro AL Single Sided Leaning 6 150kg	1.79m	3.19m	9312097064805	8.2kg
FS13959	Pro AL Single Sided Leaning 8 150kg	2.39m	3.79m	9312097064829	10.9kg

Spare Parts

SPI5-020AZ Feet Kit

PROFESSIONAL PUNCHLOCK® SINGLE SIDED LEANING STEPLADDER **NEW**

FIBREGLASS
ELECTRO-SAFE™

INDUSTRIAL

150KG

The new Bailey Pro Pro Punchlock® fibreglass single sided leaning stepladder gets you close to the worksurface improving job site safety and productivity

- 150kg load rating and industrial duty rating make it suitable for trade and commercial applications
- The Punchlock® tread design increases torsional rigidity of the overall ladder frame
- Electro-safe™ fibreglass design makes it suitable to use where an electrical hazard exists
- Unique top cap allows the ladder to be safely used as a leaning ladder
- Anti-slip PVC boots for added stability
- Flat plate tri-bracing increases strength and stability
- Made to Australian Standards AS1892



Product No.	Description	Nominal Size	Nominal Max. Reach Height	EAN Code	Nominal Weight
FS13972	Pro FG Single Sided Leaning 6 150kg	1.79m	3.19m	9312097064959	10.5kg
FS13973	Pro FG Single Sided Leaning 7 150kg	2.09m	3.49m	9312097064966	12.0kg
FS13974	Pro FG Single Sided Leaning 8 150kg	2.39m	3.79m	9312097064973	13.8kg
FS13975	Pro FG Single Sided Leaning 10 150kg	2.99m	4.39m	9312097064980	17.1kg
FS13976	Pro FG Single Sided Leaning 12 150kg	3.59m	4.99m	9312097064997	20.9kg

Spare Parts

SPI5-022AZ Feet Kit



TRADE RIVETED DOUBLE SIDED STEPLADDER

ALUMINIUM
LIGHTWEIGHT

INDUSTRIAL

150KG

- Riveted construction
- Industrial Duty Rated. Designed for use on industrial work sites where strength, durability and safety is required
- 150kg load rating
- Heavy duty extruded aluminium construction
- Internal arm system provides extra stability and resistance to ladder-walk
- Anti-slip feet for maximum grip on any surface for added safety and stability
- Made to Australian Standards AS1892

Product No.	Description	Nominal Size	Nominal Max. Reach Height	EAN Code	Nominal Weight
FS13428	TRADE AL DS 3 150kg	0.9m (3')	2.3m	9312097055629	5.9kg
FS13429	TRADE AL DS 4 150kg	1.2m (4')	2.6m	9312097055636	6.6kg
FS13430	TRADE AL DS 6 150kg	1.8m (6')	3.2m	9312097055643	9.6kg
FS13431	TRADE AL DS 8 150kg	2.4m (8')	3.8m	9312097055650	12.8kg

Spare Parts

SPI5-026AZ S/P Feet Kit



PROFESSIONAL PUNCHLOCK® BIG TOP DOUBLE SIDED STEPLADDER **NEW**

ALUMINIUM
LIGHTWEIGHT

INDUSTRIAL

150KG

The new Bailey Pro Punchlock® Big Top double sided stepladder has an extra wide top cap and base for improved stability and safety



- 150kg load rating and industrial duty rating make it suitable for trade and commercial applications
- The Punchlock® tread design increases torsional rigidity of the overall ladder frame
- The extra wide multi-function top cap provides storage for tools, improving work site safety and productivity
- Anti-slip PVC boots for added stability
- Double sided design for greater versatility and load bearing strength
- Light weight and strong aluminium construction
- Flat plate tri-bracing increases strength and stability
- Made to Australian Standards AS1892

Product No.	Description	Nominal Size	Nominal Max. Reach Height	EAN Code	Nominal Weight
FS13966	Pro AL Double Sided Big Top 3 150kg	0.89m	2.29m	9312097064898	6.1kg
FS13967	Pro AL Double Sided Big Top 4 150kg	1.19m	2.59m	9312097064904	7.5kg

Spare Parts

SPI5-021AZ Feet Kit



Multi-function top cap



Multi-function top cap

PROFESSIONAL PUNCHLOCK® DOUBLE SIDED STEPLADDER **NEW**

ALUMINIUM
LIGHTWEIGHT

INDUSTRIAL

150KG

The new Bailey Pro Punchlock® aluminium double sided stepladder multi-function top cap has a paint tin and tool holder for improved work site safety and productivity.

- 150kg load rating and industrial duty rating make it suitable for trade and commercial applications
- The Punchlock tread design increases torsional rigidity of the overall ladder frame
- The multi-function top cap provides storage for paint cans and tools improving work site safety and productivity
- Anti-slip PVC boots for added stability
- Double sided design for greater versatility and load bearing strength
- Light weight and strong aluminium construction
- Flat plate tri-bracing increases strength and stability
- Made to Australian Standards AS1892



Product No.	Description	Nominal Size	Nominal Max. Reach Height	EAN Code	Nominal Weight
FS13960	Pro AL Double Sided 3 150kg	0.89m	2.29m	9312097064836	5.6kg
FS13961	Pro AL Double Sided 4 150kg	1.19m	2.59m	9312097064843	6.9kg
FS13963	Pro AL Double Sided 6 150kg	1.79m	3.19m	9312097064867	9.8kg
FS13965	Pro AL Double Sided 8 150kg	2.39m	3.79m	9312097064881	13.7kg

Spare Parts

SPI5-021AZ Feet Kit



Multi-function top cap

PROFESSIONAL PUNCHLOCK® DOUBLE SIDED STEPLADDER **NEW**

FIBREGLASS
ELECTRO-SAFE™

INDUSTRIAL

150KG

The new Bailey Pro Punchlock® fibreglass double sided stepladder multi-function top cap has a tool holder for improved work site safety and productivity.

- 150kg load rating and industrial duty rating make it suitable for trade and commercial applications
- The Punchlock tread design increases torsional rigidity of the overall ladder frame
- Electro-safe™ fibreglass design makes it suitable to use where an electrical hazard exists
- The multi-function top cap provides storage for tools, improving work site safety and productivity
- Anti-slip PVC boots for added stability
- Double sided design for greater versatility and load bearing strength
- Flat plate tri-bracing increases strength and stability
- Made to Australian Standards AS1892



Product No.	Description	Nominal Size	Nominal Max. Reach Height	EAN Code	Nominal Weight
FS13977	Pro FG Double Sided 3 150kg	0.89m	2.29m	9312097065000	7.4kg
FS13978	Pro FG Double Sided 4 150kg	1.19m	2.59m	9312097065017	9.1kg
FS13980	Pro FG Double Sided 6 150kg	1.79m	3.19m	9312097065031	12.8kg
FS13981	Pro FG Double Sided 7 150kg	2.09m	3.49m	9312097065048	15.6kg
FS13982	Pro FG Double Sided 8 150kg	2.39m	3.79m	9312097065055	17.6g
FS13983	Pro FG Double Sided 10 150kg	2.99m	4.39m	9312097065062	22.2g
FS13984	Pro FG Double Sided 12 150kg	3.59m	4.99m	9312097065079	27.1kg

Spare Parts

SPI5-023AZ Feet Kit

MULTI-PURPOSE LADDERS



BXS 20 MULTI-PURPOSE LADDERS

ALUMINIUM
LIGHTWEIGHT

INDUSTRIAL

135KG

- Industrial Duty Rated. Designed for use on industrial work sites
- 135kg load rating
- Strong, aluminium construction
- The most versatile ladder you can own
- Telescopic design quickly adjusts to a comfortable working height
- Adjust height quickly with spring loaded 'J' locks
- Adjust angle positions easily with push knobs
- Wide flared bottom for firm support and stability
- Anti-slip feet for added safety and stability
- Made to Australian Standards AS1892

Product No.	Description	Nominal Size	Nominal Max. Reach Height	EAN Code	Nominal Weight
FS13644	BXS20 MKII Multi-Purpose 135kg	2.3/4.5m (7'6"/14'8")	3.1/5.5m	9312097060005	16.7kg

Spare Parts

SPI5-011	S/P Feet Kit
----------	--------------



Stairway ladder

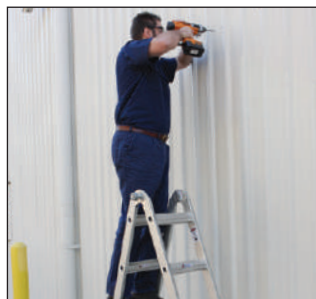

Stepladder



Straight ladder



Trestle ladder

SLS 3 IN 1 LADDERS



**AVAILABLE IN
ALUMINIUM
& FIBREGLASS**



SLS 3 IN 1 LADDERS STEP/ LEANING/ STRAIGHT LADDERS **NEW**

Clever leaning top cap

- Inside corner leaning
- Outside corner leaning
- Stud frame leaning

Patented barrel hinge

- Fast single handed operation
- Auto position lock function



Patented Barrel Hinge

ALUMINIUM LIGHTWEIGHT / **INDUSTRIAL** / **150KG**

Product No.	Description	Max. Reach Step	Max. Reach Leaning	Max. Reach Straight	EAN Code	Nominal Weight
FS13862	AL-SLS 3 IN 1 LADDER 150kg 6 (1.8m)	3.10m	3.10m	4.00m	9312097062979	8.5kg
FS13863	AL-SLS 3 IN 1 LADDER 150kg 7 (2.1m)	3.40m	3.40m	4.50m	9312097062986	9.8kg
FS13864	AL-SLS 3 IN 1 LADDER 150kg 8 (2.4m)	3.70m	3.70m	5.10m	9312097062993	11.1kg

FIBREGLASS ELECTRO-SAFE™ / **INDUSTRIAL** / **150KG**

Product No.	Description	Max. Reach Step	Max. Reach Leaning	Max. Reach Straight	EAN Code	Nominal Weight
FS13884	FG-SLS 3 IN 1 LADDER 150kg 6 (1.8m)	3.14m	3.14m	3.99m	9312097063228	11.5kg
FS13884	FG-SLS 3 IN 1 LADDER 150kg 7 (2.1m)	3.42m	3.42m	4.56m	9312097063235	13.3kg
FS13886	FG-SLS 3 IN 1 LADDER 150kg 8 (2.4m)	3.71m	3.71m	5.13m	9312097063242	15.2kg



DUAL PURPOSE & STEP EXTENSION LADDERS





PROFESSIONAL PUNCHLOCK® DUAL PURPOSE STEPLADDER

ALUMINIUM LIGHTWEIGHT / **INDUSTRIAL** / **150KG**

- Quicklatch: Converts from a straight ladder back to a stepladder with the press of a button
- Punchlock® tread design and deep fascia top caps increase torsional rigidity of the overall ladder frames
- Industrial Duty Rated. Designed for use on industrial work sites
- 150kg load rating
- Strong, aluminium construction
- Easily converts from a stepladder to a single ladder, automatically latches into position
- Slightly tapered back legs provide added stability when used as a stepladder
- Anti-slip feet for added safety and stability
- Made to Australian Standards AS1892



Product No.	Description	Nominal Size	Nominal Max. Reach Height	EAN Code	Nominal Weight
FS13395	Pro AL DP6 150kg	1.8/3.2m (6'/10')	3.2/4.2m	9312097055292	8.7kg
FS13396	Pro AL DP7 150kg	2.1/3.8m (7'/12')	3.5/4.8m	9312097055308	10.2kg
FS13397	Pro AL DP8 150kg	2.4/4.4m (8'/14')	3.8/5.4m	9312097055315	11.7kg

Spare Parts
SPI5-026AZ S/P Feet Kit



TRADE RIVETED DUAL PURPOSE STEPLADDER

ALUMINIUM LIGHTWEIGHT / **INDUSTRIAL** / **150KG**

- Riveted construction
- Industrial Duty Rated. Designed for use on industrial work sites where strength, durability and safety is required
- 150kg load rating
- Heavy duty extruded aluminium construction
- Three (3) sizes — 6, 7, 8 — a size for every height
- Ideal for trade and serious DIY
- Made to Australian Standards AS1892

Product No.	Description	Nominal Size	Nominal Max. Reach Height	EAN Code	Nominal Weight
FS13432	TRADE AL DP6 150kg	1.8/3.2m (6'/10')	3.2/4.2m	9312097055667	7.2kg
FS13433	TRADE AL DP7 150kg	2.1/3.8m (7'/12')	3.5/4.8m	9312097055674	8.4kg
FS13434	TRADE AL DP8 150kg	2.4/4.4m (8'/14')	3.8/5.4m	9312097055681	9.6kg

Spare Parts
SPI5-026AZ S/P Feet Kit



PROFESSIONAL RIVETED DUAL PURPOSE STEPLADDER WITH TREE & POLE SUPPORT

FIBREGLASS
ELECTRO-SAFE™

INDUSTRIAL

150KG

- Tree/pole support added to rear section dramatically improves stability when used against trees and poles
- Three (3) sizes — 6, 7, 8 — a size for every height
- Large anti-slip “Boots” increases stability when working at heights
- Trapezoidal tread design and deep fascia tops caps increase the torsional rigidity of the overall ladder frames
- Industrial Duty Rated. Designed for use on Industrial work sites
- 150kg Load Rate
- Electro-Safe™ (non-conductive)
- Easily converts from a stepladder to a single ladder
- Made to Australian Standards AS1892



Product No.	Description	Nominal Size	Nominal Max. Reach Height	EAN Code	Nominal Weight
FS13668	FG DP6 with Tree/Pole Support	1.8/3.2m (6'/10')	3.2/4.2m	9312097060715	10.5kg
FS13669	FG DP7 with Tree/Pole Support	2.1/3.8m (7'/12')	3.5/4.8m	9312097060722	15.1kg
FS13670	FG DP8 with Tree/Pole Support	2.4/4.4m (8'/14')	3.8/5.4m	9312097060739	16.8kg

Spare Parts

SP15-009AZ S/P Feet Kit



PROFESSIONAL PUNCHLOCK® STEP EXTENSION STEPLADDER

FIBREGLASS
ELECTRO-SAFE™

INDUSTRIAL

150KG

- Punchlock® tread design and deep fascia top caps increase torsional rigidity of the overall ladder frames
- Industrial Duty Rated. Designed for use on industrial work sites
- 150kg load rating
- Rear sliding section fits inside standard ceiling access holes
- Strong, fibreglass construction
- Electro - Safe™ (non-conductive)
- Highly versatile and easily converts from a stepladder to an extension ladder
- Rear section extends in 300mm increments
- Strong and safe extended ladder position ensured by heavy duty locking hooks
- Anti-slip rubber “Boots” for added safety, stability and protection of the stiles
- ‘Vee’ rung as standard for pole work
- Made to Australian Standards AS1892



Product No.	Description	Nominal Size	Nominal Max. Reach Height	EAN Code	Nominal Weight
FS10444	Pro FG FSE6 150KG	1.8/3.2m (6'/10')	3.2/4.2m	9312097006188	12.6kg
FS10445	Pro FG FSE7 150KG	2.1/3.8m (7'/12')	3.5/4.8m	9312097006195	14.4kg
FS10446	Pro FG FSE8 150KG	2.4/4.1m (8'/13')	3.8/5.1m	9312097006201	15.8kg

Spare Parts

SP15-30AZ S/P Feet Kit

EXTENSION & SINGLE LADDERS





TRIPLE EXT 6/14 EXTENSION LADDER **NEW**

ALUMINIUM
LIGHTWEIGHT

INDUSTRIAL
150KG

- 150kg load rating and industrial duty
- The triple section compact design provides safe access to heights up to 5.39m but is under 2m when closed.
- The compact design makes it easier to store transport and manoeuvre indoors.
- Durable punchlock D rung construction providing superior climbing comfort.
- Convenient carry handles attached for easy, single-handed carrying
- Fits in most cars when in the closed position
- Slip resistant PVC boots also increases protection of the stile ends
- More overlapping rung positions for improved foot comfort
- Made to Australian Standards AS1892

Product No.	Description	Nominal Size	Nominal Max. Reach Height	EAN Code	Nominal Weight
FS13908	Bailey Triple Ext 6/14 150kg Ind	1.95/4.39m	5.39m	9312097063983	13.5kg

Spare Parts

SP15-015AZ Feet Kit
SP45-063AZ End Caps



PROFESSIONAL PUNCHLOCK® WITH LEVELLER EXTENSION LADDER **NEW**

ALUMINIUM
LIGHTWEIGHT

INDUSTRIAL
150KG

- Factory fitted ladder levelling system allows for safe use on uneven surfaces
- 150kg load rating and industrial duty rating make it suitable for commercial applications
- Durable punchlock D rung construction providing superior climbing comfort
- Interlocking stiles provide increased resistance to side sway and bounce providing a more secure climbing experience
- Rung wear pads provide protection and easier raising and lowering of the ladder
- 8mm kernmantle rope with a side rope and pulley system that keeps the rope away from the users feet for increased safety
- PVC boots provide superior slip resistance
- Large rung braces for increased strength
- Made to Australian Standards AS1892



Product No.	Description	Nominal Size	Nominal Max. Reach Height	EAN Code	Nominal Weight
FS13905	Pro AL Ext 10 Leveller 150kg Ind	3.18/5.01m	6.01m	9312097063952	15.4kg
FS13906	Pro AL Ext 12 Leveller 150kg Ind	3.79/6.23m	7.23m	9312097063969	19.7kg

Spare Parts

SP15-016AZ Feet Kit
SP45-063AZ End Caps
SP25-004AZ Rope Kit



PROFESSIONAL PUNCHLOCK® EXTENSION LADDER **NEW**

ALUMINIUM
LIGHTWEIGHT

INDUSTRIAL
150KG

- 150kg load rating and industrial duty rating make it suitable for commercial applications
- Durable punchlock D rung construction providing superior climbing comfort
- Interlocking stiles provide increased resistance to side sway and bounce providing a more secure climbing experience
- Rung wear pads provide protection and easier raising and lowering of the ladder
- 8mm kermantle rope with a side rope and pulley system that keeps the rope away from the users feet for increased safety
- PVC boots provide superior slip resistance
- Large rung braces for increased strength
- Made to Australian Standards AS1892
- Note: FS13897 does not feature rope and pulley



Product No.	Description	Nominal Size	Nominal Max. Reach Height	EAN Code	Nominal Weight
FS13897	Pro AL Ext 8 150kg Ind	2.57/4.09m	5.09m	9312097063877	11.5kg
FS13898	Pro AL Ext 10 150kg Ind	3.18/5.31m	6.31m	9312097063884	14.3kg
FS13899	Pro AL Ext 12 150kg Ind	3.79/6.53m	7.53m	9312097063891	18.7kg
FS13900	Pro AL Ext 14 150kg Ind	4.40/7.75m	8.75m	9312097063907	21.5kg
FS13901	Pro AL Ext 16 150kg Ind	5.04/9.00m	10.00m	9312097063914	34.5kg
FS13902	Pro AL Ext 18 150kg Ind	5.65/10.22m	11.22m	9312097063921	38.5kg
FS13903	Pro AL Ext 20 150kg Ind	6.26/11.14m	12.14m	9312097063938	42.4kg

Spare Parts

SPI5-015AZ Feet Kit (for sizes: 8, 10, 12, 14)

SPI5-017AZ Feet Kit (for sizes: 16, 18, 20)

SP45-063AZ End Caps (for sizes: 8, 10, 12, 14)

SP45-064AZ End Caps (for sizes: 16, 18, 20)

SP25-004AZ S/P Rope Kit



PROFESSIONAL PUNCHLOCK® FXN WITH VEE RUNG EXTENSION LADDER **NEW**

FIBREGLASS
ELECTRO-SAFE™

INDUSTRIAL
160/170KG

- 170kg load rate on sizes 8 through to 16 and 160kg on size 18
- The Punchlock top hat construction increases resistance to bounce and side sway
- Electro - Safe™ (non-conductive) fibreglass construction is a must where electrical hazards exist
- Anti-slip PVC boots for added stability
- Adjustable pulley system allows the user to configure the rope as a side or centre pull
- Factory fitted PVC coated pole strap allows the ladder to be positioned against poles and trees
- Made to Australian Standards AS1892

Product No.	Description	Nominal Size	Nominal Max. Reach Height	EAN Code	Nominal Weight
FS13909	Pro FG FXN Ext 8 170kg Ind	2.60/4.13m	5.13m	9312097063990	21.1kg
FS13910	Pro FG FXN Ext 10 170kg Ind	3.21/5.35m	6.35m	9312097064003	25.6kg
FS13911	Pro FG FXN Ext 12 170kg Ind	3.82/6.57m	7.57m	9312097064010	30.0kg
FS13912	Pro FG FXN Ext 14 170kg Ind	4.43/7.79m	8.79m	9312097064027	34.4kg
FS13913	Pro FG FXN Ext 16 170kg Ind	5.04/9.01m	10.01m	9312097064034	38.9kg
FS13914	Pro FG FXN Ext 18 160kg Ind	5.65/9.92m	10.92m	9312097064041	43.3kg

Spare Parts

SPI5-017AZ Feet Kit

SP45-064AZ End Caps

SP25-005AZ Rope Kit



PROFESSIONAL PUNCHLOCK® FSXN WITH VEE RUNG EXTENSION LADDER **NEW**

FIBREGLASS
ELECTRO-SAFE™

INDUSTRIAL
140/150KG

- 150kg load rating on sizes 8 to 14 and 140kg on size 16
- The Punchlock® construction provides a durable rung to stile connection
- Interlocking stiles provide increased resistance to side sway providing a more secure climbing experience
- Anti-slip PVC boots for added stability
- Rung wear pads provide protection and easier raising and lowering of the ladder
- Factory fitted V rung allows the ladder to be safely positioned against poles and trees
- Made to Australian Standards AS1892



Product No.	Description	Nominal Size	Nominal Max. Reach Height	EAN Code	Nominal Weight
FS13917	Pro FG FSXN Ext 8 Vee 150kg Ind	2.63/4.16m	5.16m	9312097064058	19.3kg
FS13918	Pro FG FSXN Ext 10 Vee 150kg Ind	3.24/5.38m	6.38m	9312097064065	23.2kg
FS13919	Pro FG FSXN Ext 12 Vee 150kg Ind	3.85/6.60m	7.60m	9312097064072	27.1kg
FS13920	Pro FG FSXN Ext 14 Vee 150kg Ind	4.46/7.82m	8.82m	9312097064089	31.2kg
FS13921	Pro FG FSXN Ext 16 Vee 140kg Ind	5.07/9.04m	10.04m	9312097064096	35.1kg

Spare Parts

SP15-017AZ Feet Kit

SP45-064AZ End Caps

SP25-004AZ Rope Kit



PROFESSIONAL PUNCHLOCK® SINGLE LADDER **NEW**

ALUMINIUM
LIGHTWEIGHT

INDUSTRIAL
150KG

- 150kg load rating and industrial duty rating make it suitable for commercial applications
- Durable punchlock D rung construction providing superior climbing comfort
- PVC boots at the top and bottom of the ladder provide superior slip resistance
- Large rung braces for increased strength
- Extra heavy duty aluminium construction
- Made to Australian Standards AS1892



Product No.	Description	Nominal Size	Nominal Max. Reach Height	EAN Code	Nominal Weight
FS13890	Pro AL Single 7 150kg Ind	2.40m	3.40m	9312097063808	11.5kg
FS13891	Pro AL Single 9 150kg Ind	3.01m	4.01m	9312097063815	14.3kg
FS13892	Pro AL Single 11 150kg Ind	3.62m	4.62m	9312097063822	18.7kg
FS13893	Pro AL Single 13 150kg Ind	4.23m	5.23m	9312097063839	21.5kg

Spare Parts

SP15-015AZ Feet Kit

SP45-063AZ End Caps

PLATFORM STEPLADDERS





PROFESSIONAL PUNCHLOCK® PLATFORM STEPLADDER **NEW**

ALUMINIUM
LIGHTWEIGHT

INDUSTRIAL

170KG

The new Bailey Pro Punchlock® aluminium platform stepladder has a large and stable work platform to improve work site safety and efficiency

- 170kg load rating and industrial duty rating make it suitable for trade and commercial applications
- The Punchlock tread design increases torsional rigidity of the overall ladder frame
- Large 400 X 500mm platform for added safety and all day standing comfort
- 900mm handrail height from platform
- Anti-slip PVC boots for added stability
- Multi-function handrail for tool storage
- Safety gates and castors available as accessories
- Made to Australian Standards AS1892



**SAFETY GATE FS13952
NOW AVAILABLE**

Spare Parts

SP15-018AZ S/P Boot Kit AL & Ext. IND PFS

Product No.	Description	Nominal Platform Height	Nominal Max. Reach Height	EAN Code	Nominal Weight
FS13931	Pro AL Platform Ladder 2	0.57m	2.57m	9312097064133	8.8kg
FS13932	Pro AL Platform Ladder 3	0.85m	2.86m	9312097064140	10.0kg
FS13933	Pro AL Platform Ladder 4	1.13m	3.14m	9312097064157	11.1kg
FS13934	Pro AL Platform Ladder 5	1.42m	3.43m	9312097064164	12.3kg
FS13935	Pro AL Platform Ladder 6	1.70m	3.71m	9312097064171	14.0kg
FS13936	Pro AL Platform Ladder 7	1.99m	4.00m	9312097064188	19.5kg
FS13937	Pro AL Platform Ladder 8	2.27m	4.28m	9312097064195	21.0kg

Accessories

FS13991	Castor / Wheel Kit (White Spring) Fits 2-5 step	-	-	9312097021419	2.5kg
FS13992	Castor / Wheel Kit (Yellow Spring) Fits 6-7 step	-	-	9312097021426	2.5kg
FS13993	Castor / Wheel Kit (Green Spring) Fits 8 step	-	-	9312097065161	3.3kg
FS13952	Safety Gate Kit (Pro AL, Pro FG, P150 AL, P150 FG)	-	-	9312097060036	2.7kg

Note: Platform height is approximate vertical height to platform from the ground



P170 JOB STATION PLATFORM STEPLADDER

ALUMINIUM
LIGHTWEIGHT

INDUSTRIAL

170KG

- Huge platform area (610 x 457mm) adds comfort and stability
- New 'trapezoidal tread design' provides an incredibly strong tread to stile joint
- Fully reinforced polypropylene platform with metal inserts for maximum strength
- Checker plate 'deck pattern' provides an anti-slip standing area
- Extra strong, heavy duty aluminium construction for superior durability
- Large anti-slip feet for maximum stability and durability
- Convenient carry handle allows for easy transport
- Swivel castors for improved mobility
- Fully integrated bracing and castor system - patented industry leading design
- Made to Australian Standards AS1892

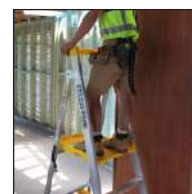

Castors Included

**P170 SAFETY GATE FS13648
NOW AVAILABLE**

Spare Parts

SP15-005AZ S/P Feet Kit

SP30-001AZ S/P Castor Kit

Product No.	Description	Nominal Platform Height	Nominal Max. Reach Height	EAN Code	Nominal Weight
FS13538	AL P170 3 Job Station	0.9m	2.87m	9312097058620	16.9kg
FS13539	AL P170 4 Job Station	1.2m	3.16m	9312097058637	18.4kg
FS13540	AL P170 5 Job Station	1.5m	3.45m	9312097058644	19.9kg
FS13541	AL P170 6 Job Station	1.8m	3.74m	9312097058651	21.9kg
FS13542	AL P170 7 Job Station	2.03m	4.03m	9312097058668	27.4kg
FS13543	AL P170 8 Job Station	2.32m	4.32m	9312097058675	28.4kg
FS13544	AL P170 10 Job Station	2.91m	4.91m	9312097058682	33.2kg
FS13545	AL P170 12 Job Station	3.49m	5.49m	9312097058699	37.6kg

Accessories

FS13594	Safety Gate Kit (P170 AL & P170 FG)	-	-	9312097064362	2.4kg
---------	-------------------------------------	---	---	---------------	-------



**SCAN TO VIEW
SAFETY GATE
DEMO VIDEO**



P150 PLATFORM STEPLADDER

ALUMINIUM LIGHTWEIGHT / **INDUSTRIAL** / **150KG**

- Lightweight and highly portable - Up to 25% lighter than competitive products
- Fully functional 'magnetised' section on handrail secures tools and fasteners
- Large standing area (508 x 416mm) adds comfort and stability
- 150kg load rating
- Industrial Duty Rating
- Checker plate 'deck pattern' provides an anti-slip standing area
- Extra strong, heavy duty aluminium construction for superior durability
- Large anti-slip feet for maximum stability and durability
- tSwivel castors for improved mobility and improved productivity (available as an accessory)
- Made to Australian Standards AS1892

P150 SAFETY GATE FS13647
NOW AVAILABLE

Spare Parts
SPI5-004AZ S/P Feet Kit

Product No.	Description	Nominal Platform Height	Nominal Max. Reach Height	EAN Code	Nominal Weight
FS13580	AL P150 3 150kg	0.9m	2.9m	9312097059191	11kg
FS13581	AL P150 4 150kg	1.2m	3.2m	9312097059207	12.5kg
FS13582	AL P150 5 150kg	1.5m	3.5m	9312097059214	13.9kg
FS13583	AL P150 6 150kg	1.8m	3.8m	9312097059221	15.8kg
Accessories					
FS13584	Castor Kit	-	-	9312097059238	3.5kg
FS13952	Safety Gate Kit (Pro AL, Pro FG, P150 AL, P150 FG)			9312097064348	2.6kg



RETAIL/ OFFICE PLATFORM STEPLADDER

ALUMINIUM LIGHTWEIGHT / **INDUSTRIAL** / **120KG**

- Large 300mm deep and 250mm wide platform provides a comfortable work position
- Multi-function flip top handrail
- Anti-slip PVC boots for added stability
- Trapezoidal tread profile for strength and durability
- 115mm deep when closed makes it easy to store when not in use
- Available in three sizes with platform heights ranging from 570mm to 1130mm providing a reach height from 2.6m to 3.1m
- 120kg load rating and industrial duty rating



RPFS top cap



Product No.	Description	Nominal Platform Height	Nominal Max. Reach Height	EAN Code	Nominal Weight
FS13868	Retail Platform Stepladder 2	0.57m	2.6m	9312097063068	4.5kg
FS13869	Retail Platform Stepladder 3	0.85m	2.9m	9312097063075	5.6kg
FS13870	Retail Platform Stepladder 4	1.13m	3.1m	9312097063082	6.9kg



PROFESSIONAL PUNCHLOCK® PLATFORM STEPLADDER **NEW**

FIBREGLASS
ELECTRO-SAFE™

INDUSTRIAL

170KG

The new Bailey Pro Punchlock® fibreglass platform stepladder has a large and stable work platform to improve work site safety and efficiency

- 170kg load rating and industrial duty rating make it suitable for trade and commercial applications
- The Punchlock tread design increases torsional rigidity of the overall ladder frame
- Large 400 X 500mm platform for added safety and all day standing comfort
- 900mm handrail height from platform
- Electro-safe™ fibreglass design makes it suitable to use where an electrical hazard exists
- Anti-slip PVC boots for added stability
- Multi-function handrail for tool storage
- Safety gates and castors available as accessories
- Made to Australian Standards AS1892

**SAFETY GATE FS13952
NOW AVAILABLE**

Spare Parts/Accessories

SP15-019AZ S/P Boot Kit FG PGS & FSE

Product No.	Description	Nominal Platform Height	Nominal Max. Reach Height	EAN Code	Nominal Weight
FS13945	Pro FG Platform Ladder 2	0.57m	2.57m	9312097064270	11.4kg
FS13946	Pro FG Platform Ladder 3	0.86m	2.86m	9312097064287	13.1kg
FS13947	Pro FG Platform Ladder 4	1.14m	3.14m	9312097064294	14.8kg
FS13948	Pro FG Platform Ladder 5	1.43m	3.43m	9312097064300	16.5kg
FS13949	Pro FG Platform Ladder 6	1.71m	3.71m	9312097064317	18.7kg
FS13950	Pro FG Platform Ladder 7	2.00m	4.00m	9312097064324	24.8kg
FS13951	Pro FG Platform Ladder 8	2.28m	4.28m	9312097064331	26.8kg
Accessories				EAN Code	
FS13991	Castor / Wheel Kit (White Spring) Fits 2-3 step	-	-	9312097021419	2.5kg
FS13992	Castor / Wheel Kit (Yellow Spring) Fits 4-6 step	-	-	9312097021426	2.5kg
FS13993	Castor / Wheel Kit (Green Spring) Fits 7-8 step	-	-	9312097065161	3.3kg
FS13952	Safety Gate Kit (Pro AL, Pro FG, P150 AL, P150 FG)	-	-	9312097060036	2.7kg

Note: Platform height is approximate vertical height to platform from the ground



P170 JOB STATION PLATFORM STEPLADDER

FIBREGLASS
ELECTRO-SAFE™

INDUSTRIAL

170KG

- Huge platform area (610 x 457mm) adds comfort and stability
- New 'trapezoidal tread design' provides an incredibly strong tread to stile joint
- Multi-function handrail with optional 'DropLok' accessories converts a handrail into a Job Station (15kg capacity)
- Fully reinforced polypropylene platform with metal inserts for maximum strength
- Electro - Safe™ (non-conductive)
- Checker plate 'deck pattern' provides an anti-slip standing area
- Extra strong, heavy duty fibreglass construction for superior durability
- Large anti-slip feet for maximum stability and durability
- Convenient carry handle allows for easy transport for improved mobility and improved productivity
- Fully integrated bracing and castor system - patented industry leading design
- Made to Australian Standards AS1892



Carry Handle

Product No.	Description	Nominal Platform Height	Nominal Max. Reach Height	EAN Code	Nominal Weight
FS13530	FG P170 3 Job Station	0.9m	2.9m	9312097058545	17.9kg
FS13531	FG P170 4 Job Station	1.2m	3.2m	9312097058552	19.5kg
FS13532	FG P170 5 Job Station	1.5m	3.5m	9312097058569	21.2kg
FS13533	FG P170 6 Job Station	1.8m	3.8m	9312097058576	23.4kg
FS13534	FG P170 7 Job Station	2.03m	4.03m	9312097058583	29kg
FS13535	FG P170 8 Job Station	2.32m	4.32m	9312097058590	30.3kg
FS13536	FG P170 10 Job Station	2.91m	4.91m	9312097058606	35.3kg
FS13537	FG P170 12 Job Station	3.49m	5.49m	9312097058613	40.1kg
Accessories					
FS13954	Safety Gate Kit (P170 AL & P170 FG)	-	-	9312097064362	2.4kg



**SCAN TO VIEW
P170 VIDEO**

Spare Parts

SP15-005AZ S/P Feet Kit

SP30-001AZ S/P Castor Kit



P150 PLATFORM STEPLADDER

FIBREGLASS ELECTRO-SAFE™ **INDUSTRIAL** **150KG**

- Lightweight and highly portable – Up to 25% lighter than competitive products
- Fully functional ‘magnetised’ handrail secures tools and fasteners
- Electro – Safe™ (non-conductive)
- Large standing area (508 x 416mm) adds comfort and stability
- 150kg load rating
- Checker plate ‘deck pattern’ provides an anti-slip standing area
- Heavy duty fibreglass construction for superior durability
- Large anti-slip feet for maximum stability and durability
- Swivel castors for improved mobility and improved productivity (available as an accessory)
- Made to Australian Standards AS1892



Spare Parts

SP15-009AZ S/P Feet Kit

Product No.	Description	Nominal Platform Height	Nominal Max. Reach Height	EAN Code	Nominal Weight
FS13576	HD FG P150 3 150kg	0.9m	2.9m	9312097059153	12.1kg
FS13577	HD FG P150 4 150kg	1.2m	3.2m	9312097059160	13.8kg
FS13578	HD FG P150 5 150kg	1.5m	3.5m	9312097059177	15.4kg
FS13579	HD FG P150 6 150kg	1.8m	3.8m	9312097059184	17.5kg
Accessories					
FS13584	Castor Kit	-	-	9312097059238	3.5kg
FS13952	Safety Gate Kit (Pro AL, Pro FG, P150 AL, P150 FG)			9312097064348	2.7kg



SAFETY GATE FOR PLATFORM STEPLADDERS

- Fully surrounds the user
- Improves safety on platform stepladders
- Maintains a safe working zone
- Folds down for easy access
- Folds away with ladder
- Quick and easy to fit
- Simple to use
- Ladder still fits on roof racks
- Safety gates will fit previous models of platform stepladders



Product No.	Description	EAN Code	Nominal Weight
FS13952	Safety Gate Kit (Pro AL, Pro FG, P150 AL, P150 FG)	9312097064348	2.7kg
FS13953	Safety Gate Kit (Ext Industry & Ladderweld)	9312097064355	2.6kg
FS13954	Safety Gate Kit (P170 AL & P170 FG)	9312097064362	2.4kg

ACCESSORIES FOR PLATFORM STEPLADDERS

Product No.	Description	EAN Code	Nominal Weight
FS13991	Castor / Wheel Kit (White Spring) – Fits 2-3 step	9312097065147	3.3kg
FS13992	Castor / Wheel Kit (Yellow Spring) – Fits 4-6 step	9312097065154	3.3kg
FS13993	Castor / Wheel Kit (Green Spring) – Fits 7-8 step	9312097065161	3.3kg
FS13952	Safety Gate Kit	9312097064348	2.6kg

SAFETY STEPS



SAFETY STEPS

ALUMINIUM
LIGHTWEIGHT

INDUSTRIAL

150KG

Bailey's NEW Safety Step provides stair like access and is ultra compact when folded and not in use

- Light weight aluminium construction
- Slim profile for easy storage when not in use
- Wide and deep treads with anti-slip rubber insert for safety and stability
- Racked front frame for stair-like access
- Strong 150kg load rating
- Folding handrail comes as standard
- Made to the Australian Standard AS1892



Product No.	Description	Size	Maximum Reach Height	EAN Code	Weight
FS13750	Stairway Ladder 2 Step with Safety Rail 150kg Ind	0.45m	2.45m	9312097061842	6.6kg
FS13751	Stairway Ladder 3 Step with Safety Rail 150kg Ind	0.67m	2.67m	9312097061859	8.6kg
FS13752	Stairway Ladder 4 Step with Safety Rail 150kg Ind	0.89m	2.89m	9312097061866	10.6kg
FS13753	Stairway Ladder 5 Step with Safety Rail 150kg Ind	1.11m	3.11m	9312097061873	12.7kg

ATTIC LADDERS



ATTIC LADDER

ALUMINIUM LIGHTWEIGHT **DOMESTIC** **170KG**

- Designed for domestic applications
- Strong and stable aluminium construction
- Standard ceilings (2.34-3.12m) 170kg Domestic duty rating
- Gas struts provide easy and quiet opening
- Handrail included for additional comfort when climbing
- Wide opening for easy access
- Simple and easy to install



Product No.	Description	Nominal Size	Nominal Opening Dimensions	EAN Code	Nominal Weight
FS13560	AL Attic Ladder 170kg	2.34m — 3.12m	570 x 1370mm approx.	9312097058842	22.0kg



ORDER PICKERS & ACCESS PLATFORMS



Note: Access Platform FS13591 shown



- Safety gate now a standard inclusion
- Supplied in flat pack assembly with detailed assembly instructions.

ORDER PICKING PLATFORMS TEMPORARY WORK PLATFORM

ALUMINIUM
LIGHTWEIGHT

INDUSTRIAL

150KG

BAILEY
Ladderweld

- Industrial Duty Rated order picking ladder designed for use on commercial sites and warehouses
- 150kg load rating
- Light, strong aluminium construction with heavy duty stiles and tread
- Safety gate included as standard
- Rear Tilt-N-Go castors
- Large 600 X 500mm platform
- Box section back legs provide greater strength and rigidity
- Ideal for stock picking or industrial applications
- Spring loaded castors for ease of manoeuvrability
- Supplied flat packed with the tools required for assembly
- Made to Australian Standards AS1892

Product No.	Description	Nominal Platform Height	Nominal Max. Reach Height	EAN Code	Nominal Weight
FS13873	Order Picking Platform 2 MK3	0.55m	2.55m	9312097063112	20.0kg
FS13874	Order Picking Platform 3 MK3	0.82m	2.82m	9312097063129	22.1kg
FS13875	Order Picking Platform 4 MK3	1.10m	3.10m	9312097063136	24.0kg
FS13876	Order Picking Platform 5 MK3	1.38m	3.38m	9312097063143	25.9kg
FS13877	Order Picking Platform 6 MK3	1.65m	3.65m	9312097063150	28.5kg
FS13878	Order Picking Platform 7 MK3	1.93m	3.93m	9312097063167	30.5kg
FS13879	Order Picking Platform 8 MK3	2.20m	4.20m	9312097063174	32.7kg



LADDERWELD ACCESS PLATFORM TEMPORARY WORK PLATFORM

ALUMINIUM
LIGHTWEIGHT

INDUSTRIAL

200KG

BAILEY
Ladderweld

- Super strong 'fully welded' design fabricated from heavy duty aluminium
- 100mm deep treads improve safety and comfort when climbing
- 'Walk thru' design for stock picking and access to mezzanine floors, vehicle access and warehousing
- Large 125mm wheels – improved portability and 'easy glide' action
- Large stable work platform (safe and stable) – 590mm x 800mm
- Manually operated braking system with high-vis powder coated activation arm helps minimize unauthorised access
- Toe board on three sides (helps secure tools/ accessories)
- Shelf included
- 200kg load rating
- Industrial duty rating for use on commercial sites
- Meets OH&S requirements (safety gate + 900mm handrail, toe board)
- Made to Australian Standards AS1892



SCAN TO
VIEW ACCESS
PLATFORMS
VIDEO



SCAN TO VIEW
ASSEMBLY
VIDEO

Spare Parts

Please refer to pages 32-33 of this product guide.

Product Code	Description	Nominal Platform Height	Nominal Max. Reach Height	EAN Code	Nominal Fully Open Dimensions (WxD mm)	Nominal Weight
FS13591	Access Platform 3	828mm	2.8m	9312097059436	724 x 1168	38.1kg
FS13592	Access Platform 4	1104mm	3.1m	9312097059443	764 x 1309	40.6kg
FS13593	Access Platform 5	1381mm	3.4m	9312097059450	804 x 1451	43kg
FS13594	Access Platform 6	1656mm	3.7m	9312097059467	844 x 1592	46kg
FS13595	Access Platform 7	1933mm	3.9m	9312097059474	884 x 1733	48.5kg
FS13596	Access Platform 8	2209mm	4.2m	9312097059481	924 x 1875	51kg
FS13597	Access Platform 10	2761mm	4.8m	9312097059498	1003 x 2157	62kg
FS13598	Access Platform 12	3313mm	5.3m	9312097059504	1083 x 2440	69kg
FS13599	Access Platform 14	3866mm	5.9m	9312097059511	1164 x 2723	76.4kg

MODULAR ACCESS/ PLATFORM SYSTEMS



1m Bridge Configuration

MODULAR ACCESS/ PLATFORM SYSTEMS

ALUMINIUM
LIGHTWEIGHT

INDUSTRIAL

200KG

Introducing the brand new Modular Access System that will revolutionise safe access to heights when used in conjunction with the Bailey Access Platforms. The modular components allow you to design and build an access platform that is customised to your needs.



2m Bridge Configuration



- Modular system allows for unlimited types of configuration
- Fully welded frames and platforms with integrated toe boards
- Hand rails can be easily removed /reposition to allow clear access to the work space
- 600mm wide platforms for a safe work zone
- Strong 200kg load rating per bay
- Industrial duty - safe to use on a work site
- Lockable castors allow easy repositioning of the system
- Made to the Australian Standard AS1892



SCAN TO VIEW
MAS VIDEO



SCAN TO VIEW
ASSEMBLY
VIDEO



Combination variable height
1m & 2m Bridge Configuration

Product No.	Description	Size	Nominal Max. Reach Height	EAN Code	Nominal Weight
FS13789	Modular Access System 1.0m Platform	1.0 m	N/A	9312097062238	16.5kg
FS13790	Modular Access System 2.0m Platform	2.0 m	N/A	9312097062245	31.0kg
FS13791	Modular Access System 3 Step Upright	0.83m	2.8m	9312097062252	7.9kg
FS13792	Modular Access System 4 Step Upright	1.10 m	3.1m	9312097062269	8.5kg
FS13793	Modular Access System 5 Step Upright	1.38m	3.4m	9312097062276	9.2kg
FS13794	Modular Access System 6 Step Upright	1.65m	3.6m	9312097062283	10.0kg
FS13855	New! Modular Access System Plus Platform	-	-	9312097062900	20.4kg
FS13856	New! Modular Access System Joiner Platform	-	-	9312097062917	8.6kg
FS13857	New! Modular Access System Plus Platform - Spreader	-	-	9312097062924	2.0kg

MOBILE SCAFFOLDING





- Tested and manufactured to AS/NZS 1576 Part 1 : 2010 and AS/NZS 1576 Part 3 : 2015
- 225kg Working Load Limit
- Lightweight aluminium construction
- Fully welded construction
- Highly portable (fits in most cars)
- DIY erection (no specialist assembly for working heights < 4 metres)
- Multiple safety features
- Full set of components increases reach height up to 5.4 metres
- Full set of spares available
- Wide, non-slip platform for working safely at heights
- Lockable 150mm industrial castors
- Exterior grade plywood platform with self-locking trapdoor
- Platform supported by aluminium sub-frame
- Wind lock prevents accidental uplift
- Adjustable height leg/ castors available as an accessory

SELECT THE RIGHT SCAFFOLD CONFIGURATION

PLATFORM HEIGHT	REACH HEIGHT*	BASE PACK FS13672	EXTENSION PACK FS13673	GUARD RAIL FS13674	TOEBOARD FS13676	LADDER FS13678	OUTRIGGER FS13677	HORIZONTAL BRACING FS13681	EXPANSION PACK FS13675
1.5m	3.5m	1		OPTIONAL	OPTIONAL		OPTIONAL		AVAILABLE
2.3m	4.3m	1	1		1	1	2	2	AVAILABLE
3.4m	5.4m	1	1	1	1	1	2		AVAILABLE

*Assumes a 1.70m person with a vertical 0.30m reach



CONFIGURATION 1A
PLATFORM HEIGHT 1.5m
Base Pack



CONFIGURATION 1B
PLATFORM HEIGHT 1.5m
Base Pack +
Guard Rail Pack



CONFIGURATION 2
PLATFORM HEIGHT 2.3m
Base Pack +
Extension Pack +
Ladder +
Horizontal Bracing +
Toe Boards +
Outrigger Pack



CONFIGURATION 3
PLATFORM HEIGHT 3.4m
Base Pack +
Extension Pack +
Guard Rail Pack +
Ladder +
Toe Boards +
Outrigger Pack



CONFIGURATION 4
PLATFORM HEIGHT 3.4m
Base Pack (2) +
Extension Pack (2) +
Guard Rail Pack (2) +
Ladder +
Toe Boards +
Expansion Pack

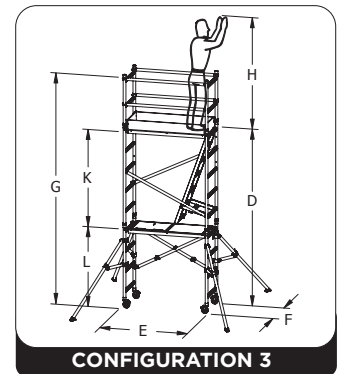
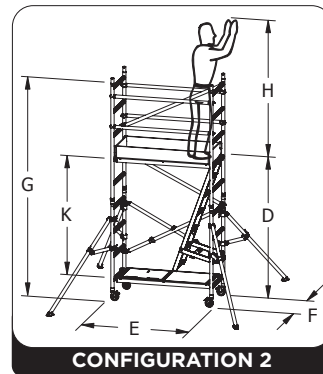
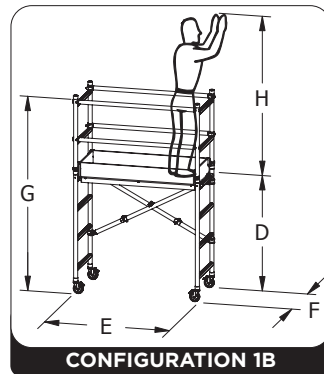
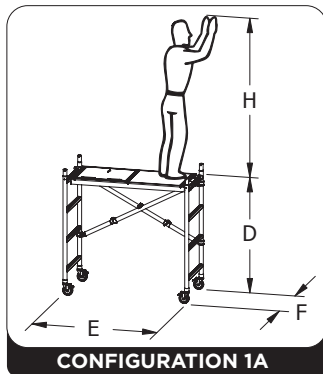



Configuration	Pack Requirements	D (mm)	E (mm)	F (mm)	G (mm)	H (mm)	K (mm)	L (mm)
1A	Base Pack	1500	1623	752	N/A	3500	N/A	N/A
1B	Base + Guardrail Packs	1500	1623	752	2500	3500	N/A	N/A
2	Base Pack + Extension Pack + Ladder + Horizontal Bracing + Toe Boards + Outrigger Pack	2300	1623	752	3300	4300	1910	N/A
3	Base Pack + Extension Pack + Guard Rail Pack + Ladder + Toe Boards + Outrigger Pack	3400	1623	752	4400	5400	1910	1500

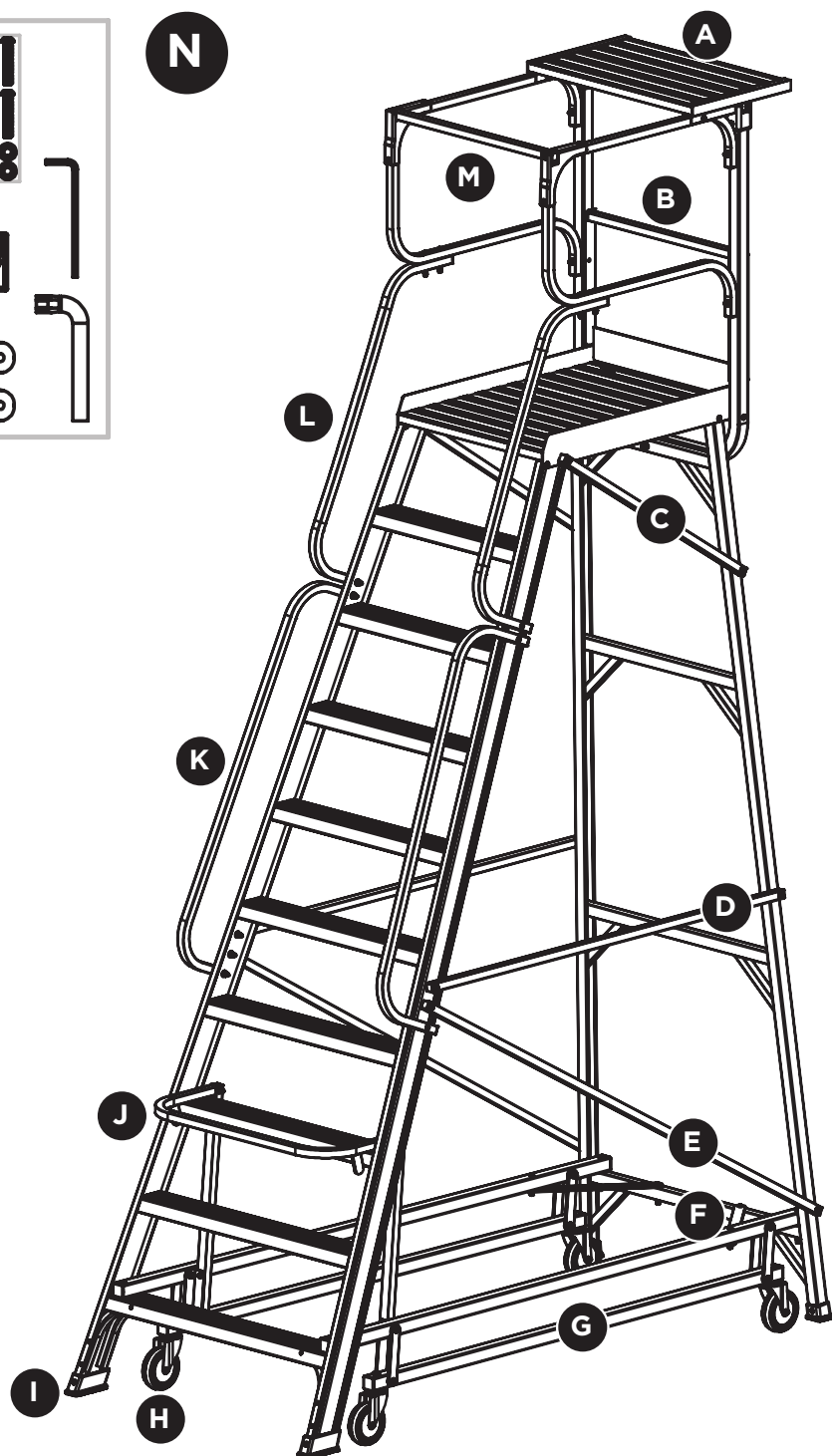
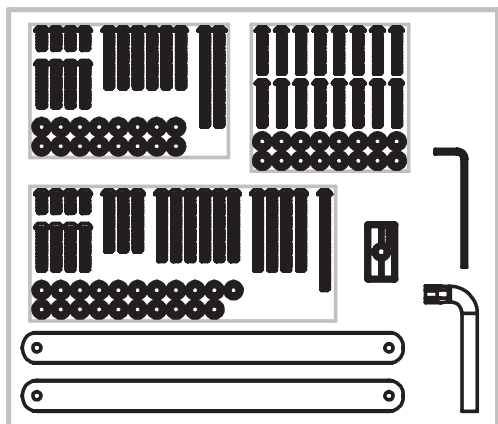

LADDERWELD ACCESS PLATFORM

TEMPORARY WORK PLATFORM
SPARE PARTS DIAGRAM



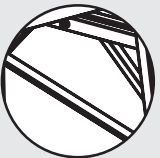

A  **Shelf**
SP45-004AZ

B  **Rear Panel**
SP45-008AZ

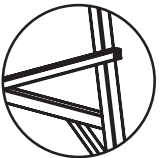
C  **Top Diagonal Braces (x2)**
SP45-009AZ

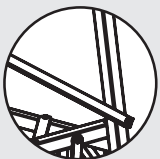
D  **Horizontal Braces (x2)**
(Access Platform 10-14)
SP45-010AZ

E  **Bottom Diagonal Braces (x2)**
(Access Platform 10-14)
SP45-011AZ

F  **Plan Braces (x2)**
SP45-012AZ

G  **Wheel System**
(RHS & LHS)
Access Plat. 3 SP45-013AZ
Access Plat. 4 SP45-014AZ
Access Plat. 5 SP45-015AZ
Access Plat. 6 SP45-016AZ
Access Plat. 7 SP45-017AZ
Access Plat. 8 SP45-018AZ
Access Plat. 10 SP45-019AZ
Access Plat. 12 SP45-020AZ
Access Plat. 14 SP45-021AZ

H  **Castors (x4)**
SP45-031AZ

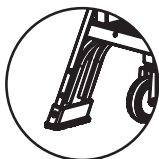
I  **Feet (Front & Rear)**
SP45-032AZ

J  **Handle and Handlevers**
Access Plat. 3 SP45-022AZ
Access Plat. 4 SP45-023AZ
Access Plat. 5 SP45-024AZ
Access Plat. 6 SP45-025AZ
Access Plat. 7 SP45-026AZ
Access Plat. 8 SP45-027AZ
Access Plat. 10 SP45-028AZ
Access Plat. 12 SP45-029AZ
Access Plat. 14 SP45-030AZ

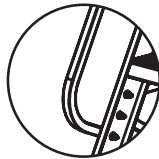
K  **Lower Handrails (x2)**
(Access Platform 10-14)
SP45-007AZ

L  **Lower Handrails (x2)**
(Access Platform 10-14)
SP45-007AZ

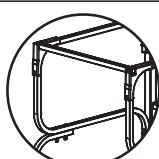
M  **RH Top Handrail
LH Top Handrail
Safety Gates (x2)**
SP45-005AZ

N  **Component Kit**
SP45-03AZ

Item Number	Product Description	Page No.
FSI0444	Pro FG FSE6 150kg Ind Punchlock* (1.8m/3.2m)	15
FSI0445	Pro FG FSE7 150kg Ind Punchlock* (2.1m/3.8m)	15
FSI0446	Pro FG FSE8 150kg Ind Punchlock* (2.4m/4.1m)	15
FSI3977	Pro FG Double Sided 3	10
FSI3978	Pro FG Double Sided 4	10
FSI3980	Pro FG Double Sided 6	10
FSI3981	Pro FG Double Sided 7	10
FSI3982	Pro FG Double Sided 8	10
FSI3983	Pro FG Double Sided 10	10
FSI3984	Pro FG Double Sided 12	10
FSI3972	Pro FG Single Sided 6 150kg	8
FSI3973	Pro FG Single Sided 7 150kg	8
FSI3974	Pro FG Single Sided 8 150kg	8
FSI3975	Pro FG Single Sided 10 150kg	8
FSI3976	Pro FG Single Sided 12 150kg	8
FSI3945	Pro FG Platform Ladder 2	23
FSI3946	Pro FG Platform Ladder 3	23
FSI3947	Pro FG Platform Ladder 4	23
FSI3948	Pro FG Platform Ladder 5	23
FSI3949	Pro FG Platform Ladder 6	23
FSI3950	Pro FG Platform Ladder 7	23
FSI3951	Pro FG Platform Ladder 8	23
FSI3873	AL Order Picking Platform 2 MK3 150kg IND Ladderweld (Platform Height: 0.55m)	28
FSI3874	AL Order Picking Platform 3 MK3 150kg IND Ladderweld (Platform Height: 0.82m)	28
FSI3875	AL Order Picking Platform 4 MK3 150kg IND Ladderweld (Platform Height: 1.10m)	28
FSI3876	AL Order Picking Platform 5 MK3 150kg IND Ladderweld (Platform Height: 1.38m)	28
FSI3877	AL Order Picking Platform 6 MK3 150kg IND Ladderweld (Platform Height: 1.65m)	28
FSI3878	AL Order Picking Platform 7 MK3 150kg IND Ladderweld (Platform Height: 1.93m)	28
FSI3878	AL Order Picking Platform 8 MK3 150kg IND Ladderweld (Platform Height: 2.20m)	28
FSI3957	Pro AL Single Sided 6 150kg	8
FSI3959	Pro AL Single Sided 8 150kg	8
FSI3960	Pro AL Double Sided 3 150kg	10
FSI3961	Pro AL Double Sided 4 150kg	10
FSI3963	Pro AL Double Sided 6 150kg	10
FSI3965	Pro AL Double Sided 8 150kg	10
FSI3966	Pro AL Doube Sided Big Top 3 150kg	9
FSI3967	Pro AL Doube Sided Big Top 4 150kg	9
FSI3395	Pro AL DP6 150kg Ind Punchlock* - 1.8m/3.2m	14
FSI3396	Pro AL DP7 150kg Ind Punchlock* - 2.1m/3.8m	14
FSI3397	Pro AL DP8 150kg Ind Punchlock* - 2.4m/4.4m	14
FSI3931	Pro AL Platform Ladder 2	21
FSI3932	Pro AL Platform Ladder 3	21
FSI3933	Pro AL Platform Ladder 4	21
FSI3934	Pro AL Platform Ladder 5	21
FSI3935	Pro AL Platform Ladder 6	21
FSI3428	Trade AL DS3 150kg Ind Riveted - 0.9m	9
FSI3429	Trade AL DS4 150kg Ind Riveted - 1.2m	9
FSI3430	Trade AL DS6 150kg Ind Riveted - 1.8m	9
FSI3431	Trade AL DS8 150kg Ind Riveted - 2.4m	9
FSI3432	Trade AL DP6 150kg Ind Riveted - 1.8m/3.2m	14
FSI3433	Trade AL DP7 150kg Ind Riveted - 2.1m/3.8m	14
FSI3434	Trade AL DP8 150kg Ind Riveted - 2.4m/4.4m	14
FSI3530	FG P170-3 170kg Ind Job Station	23
FSI3531	FG P170-4 170kg Ind Job Station	23
FSI3532	FG P170-5 170kg Ind Job Station	23
FSI3533	FG P170-6 170kg Ind Job Station	23
FSI3534	FG P170-7 170kg Ind Job Station	23
FSI3535	FG P170-8 170kg Ind Job Station	23
FSI3536	FG P170-10 170kg Ind Job Station	23
FSI3537	FG P170-12 170kg Ind Job Station	23
FSI3538	AL P170-3 170kg Ind Job Station	21
FSI3539	AL P170-4 170kg Ind Job Station	21
FSI3540	AL P170-5 170kg Ind Job Station	21
FSI3541	AL P170-6 170kg Ind Job Station	21
FSI3542	AL P170-7 170kg Ind Job Station	21
FSI3543	AL P170-8 170kg Ind Job Station	21
FSI3544	AL P170-10 170kg Ind Job Station	21
FSI3545	AL P170-12 170kg Ind Job Station	21

Item Number	Product Description	Page No.
FSI3908	Bailey Triple Ext 6/14 150kg Ind	17
FSI3560	Dom 170kg Aluminium Folding Attic Ladder - (2.34m/3.12m)	26
FSI3576	HD FG P150-3 150kg Ind Riveted	24
FSI3577	HD FG P150-4 150kg Ind Riveted	24
FSI3578	HD FG P150-5 150kg Ind Riveted	24
FSI3579	HD FG P150-6 150kg Ind Riveted	24
FSI3580	HD AL P150-3 150kg Ind Riveted	22
FSI3581	HD AL P150-4 150kg Ind Riveted	22
FSI3582	HD AL P150-5 150kg Ind Riveted	22
FSI3583	HD AL P150-6 150kg Ind Riveted	22
FSI3584	Castor Kit - P150	22
FSI3936	Pro AL Platform Ladder 7	21
FSI3937	Pro AL Platform Ladder 8	21
FSI3591	Access Platform 3 170kg Ind (Platform Height 828mm)	28
FSI3592	Access Platform 4 170kg Ind (Platform Height 1104mm)	28
FSI3593	Access Platform 5 170kg Ind (Platform Height 1381mm)	28
FSI3594	Access Platform 6 170kg Ind (Platform Height 1656mm)	28
FSI3595	Access Platform 7 170kg Ind (Platform Height 1933mm)	28
FSI3596	Access Platform 8 170kg Ind (Platform Height 2209mm)	28
FSI3597	Access Platform 10 170kg Ind (Platform Height 2761mm)	28
FSI3598	Access Platform 12 170kg Ind (Platform Height 3313mm)	28
FSI3599	Access Platform 14 170kg Ind (Platform Height 3866mm)	28
FSI3614	Pro AL Single 7 150kg Ind Punchlock®	19
FSI3615	Pro AL Single 9 150kg Ind Punchlock®	19
FSI3616	Pro AL Single 11 150kg Ind Punchlock®	19
FSI3617	Pro AL Single 13 150kg Ind Punchlock®	19
FSI3897	Pro AL Ext 8 150kg Ind Punchlock®	18
FSI3898	Pro AL Ext 10 150kg Ind Punchlock®	18
FSI3899	Pro AL Ext 12 150kg Ind Punchlock®	18
FSI3900	Pro AL Ext 14 150kg Ind Punchlock®	18
FSI3901	Pro AL Ext 16 150kg Ind Punchlock®	18
FSI3902	Pro AL Ext 18 150kg Ind Punchlock®	18
FSI3903	Pro AL Ext 20 150kg Ind Punchlock®	18
FSI3905	Pro AL Ext 10 Leveller 150kg Ind Punchlock®	17
FSI3906	Pro AL Ext 12 Leveller 150kg Ind Punchlock®	17
FSI3644	BXS20 2.3m/4.5m (7'6"/14'8") - 135kg	11
FSI3647	PFS Narrow Safety Gate Kit (suits Bailey Pro-Punchlock & P150 models)	24
FSI3648	PFS Wide Safety Gate Kit (suits Bailey P170 models)	24
FSI3668	HD FG DP6 with V Rung 150kg Riveted - 1.8m/3.2m	15
FSI3669	HD FG DP7 with V Rung 150kg Riveted - 2.1m/3.8m	15
FSI3670	HD FG DP8 with V Rung 150kg Riveted - 2.4m/4.4m	15
FSI3672	SUPA-LITE AL Scaffold System - Base Pack	31
FSI3673	SUPA-LITE AL Scaffold System - Extension Pack	31
FSI3674	SUPA-LITE AL Scaffold System - Guardrail Pack	31
FSI3675	SUPA-LITE AL Scaffold System - Expansion Pack	31
FSI3676	SUPA-LITE AL Scaffold System - Toe Board Pack	31
FSI3677	SUPA-LITE AL Scaffold System - Outrigger Pack (X2)	31
FSI3678	SUPA-LITE AL Scaffold System - Ladder	31
FSI3679	SUPA-LITE AL Scaffold System - Adjustable Legs (X2)	31
FSI3680	SUPA-LITE AL Scaffold System - Spigot Pack (X4)	31
FSI3681	SUPA-LITE AL Scaffold System - Horizontal Brace (X2)	31
FSI3682	SUPA-LITE AL Scaffold System - Diagonal Brace (X2)	31
FSI3683	SUPA-LITE AL Scaffold System - Platform (X1)	31
FSI3750	Stairway Ladder 2 Step with Safety Rail 150kg Ind	25
FSI3751	Stairway Ladder 3 Step with Safety Rail 150kg Ind	25
FSI3752	Stairway Ladder 4 Step with Safety Rail 150kg Ind	25
FSI3753	Stairway Ladder 5 Step with Safety Rail 150kg Ind	25
FSI3789	Modular Access System 1.0m Platform	29
FSI3790	Modular Access System 2.0m Platform	29
FSI3791	Modular Access System 3 Step Upright	29
FSI3792	Modular Access System 4 Step Upright	29
FSI3793	Modular Access System 5 Step Upright	29
FSI3794	Modular Access System 6 Step Upright	29
FSI3855	Modular Access System Plus Platform	29
FSI3856	Modular Access System Joiner Platform	29
FSI3857	Modular Access System Plus Platform Spreader	29
FSI3862	AL-SLS 3 IN 1 (6/9 Step) 1.8m 150kg Ind	12
FSI3863	AL-SLS 3 IN 1 (7/11 Step) 2.1m 150kg Ind	12

Item Number	Product Description	Page No.
FS13864	AL-SLS 3 IN 1 (8/14 Step) 2.4m 150kg Ind	12
FS13884	FG-SLS 3 IN 1 (6/9 Step) 1.8m 150kg Ind	12
FS13885	FG-SLS 3 IN 1 (7/11 Step) 2.1m 150kg Ind	12
FS13886	FG-SLS 3 IN 1 (8/14 Step) 2.4m 150kg Ind	12
FS13868	Retail Platform Step Stool 2 - 120kg Ind	22
FS13869	Retail Platform Step Stool 3 - 120kg Ind	22
FS13870	Retail Platform Step Stool 4 - 120kg Ind	22
FS13909	Pro FG FXN Ext 8 Vee 150kg Ind Punchlock®	18
FS13910	Pro FG FXN Ext 10 Vee 150kg Ind Punchlock®	18
FS13911	Pro FG FXN Ext 12 Vee 150kg Ind Punchlock®	18
FS13912	Pro FG FXN Ext 14 Vee 150kg Ind Punchlock®	18
FS13913	Pro FG FXN Ext 16 Vee 140kg Ind Punchlock®	18
FS13914	Pro FG FXN Ext 18 Vee 140kg Ind Punchlock®	18
FS13917	Pro FG FSXN Ext 8 Vee 150kg Ind Punchlock®	19
FS13918	Pro FG FSXN Ext 10 Vee 150kg Ind Punchlock®	19
FS13919	Pro FG FSXN Ext 12 Vee 150kg Ind Punchlock®	19
FS13920	Pro FG FSXN Ext 14 Vee 150kg Ind Punchlock®	19
FS13921	Pro FG FSXN Ext 16 Vee 140kg Ind Punchlock®	19

BAILEY**WERNER****KNAACK**

ladderspares.com.au

FINALLY, WE MADE FINDING 'LADDER SPARE PARTS' EASY!

TO IDENTIFY WHICH SPARES ARE AVAILABLE, SIMPLY LOGIN TO WWW.LADDERSPARES.COM.AU AND FOLLOW THE PROMPTS.



**SCAN TO VISIT
OUR NEW
WEBSITE**

HOW TO FIND SPARE PARTS

Step 1

Scan this QR code using your smart phone or login to www.ladderspares.com.au

Step 2

If you know the actual code of the ladder, enter this into the 'Enter Product Code' cell.

If you don't know the code, continue using the search criteria below this field.

Step 3

Select the ladder brand (Bailey, Werner, Knaack, etc).

Step 4

Select the ladder type or design.
For example, a double sided stepladder

Step 5

What material is the ladder made from?
For example, fibreglass or aluminium

Step 6

Is the ladder riveted or Punchlock?

Step 7

What size is the ladder? Count the number of treads or rungs, Eg. 6 foot

Step 8

Select the Load Rating of the ladder (100-170kg).

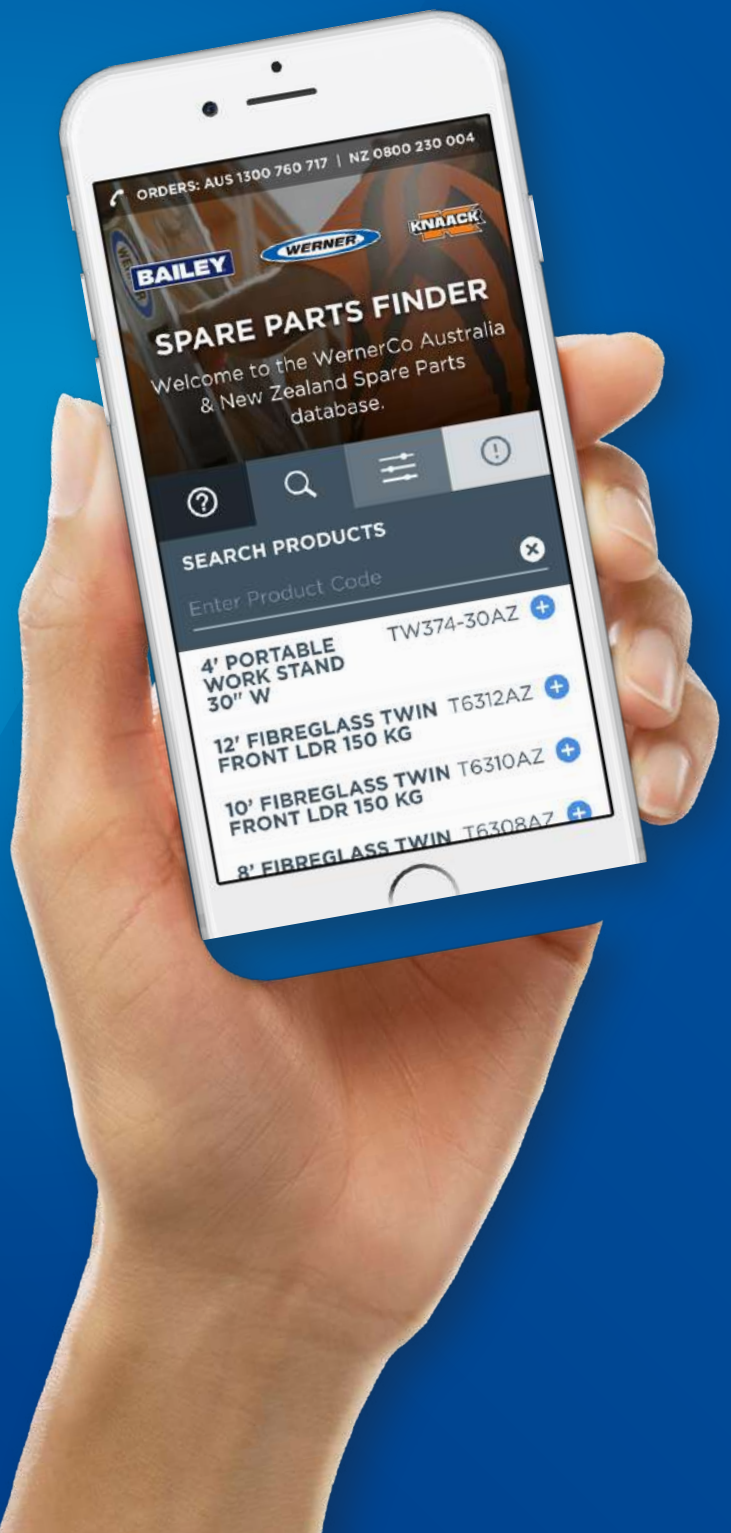



**FOR FURTHER INFORMATION,
PLEASE CONTACT OUR CUSTOMER
CARE CENTRE 1300 760 717**

BAILEYLADDERS.COM.AU

Orders: AUS.Orders@wernerco.com

Claims: AUS.RMA@wernerco.com

WERNERCO™

WernerCo Australia Pty Ltd A.B.N. 88 151 127 061

All details in this brochure are correct at time of printing.
WernerCo Australia reserves the right to alter product
specifications at any time without notice.

Doc No. DOC20.0116 ©2021 Werner Co. BAI 052021



UV RESISTANT
BUILT FOR HARSH AUSTRALIAN CONDITIONS

NON-CONDUCTIVE
SAFE FOR ELECTRICAL WORK

FIBREGLASS DOUBLE SIDED STEP LADDERS

150KG RATED | AS 1892
LENGTHS .9m - 3.6m

LIGHTWEIGHT

Strongest double hollow step treads

STRENGTH

Swagelock step tread connection **50% stronger** and **stronger** full gusset base brace - "GUSSET GUTZ"
UV RESISTANT FIBREGLASS - lasts longer and better value

SOLID FOUNDATION

Large solid feet - plated for **extra support**
Side arm locks **improve rigidity** and **reduces twist**



CODE	LENGTH [m]	WIDTH [mm]	WEIGHT [kg]	TRANSPORT CUBE [m³]
FDS032	.90	435	6	.07
FDS042	1.20	470	8	.10
FDS062	1.80	545	12	.17
FDS082	2.40	620	16	.26
FDS102	3.00	695	22	.36
FDS122	3.60	770	26	.49

All measurements are nominal and do not indicate 'exact weights and measures'



PROUDLY AUSTRALIAN MADE

LADaMAX[®]
AUSTRALIA'S LADDER SPECIALIST

www.ladamax.com.au

admin@ladamax.com.au

07 3205 7698